

CityCat 2020 SL/XL Specifications

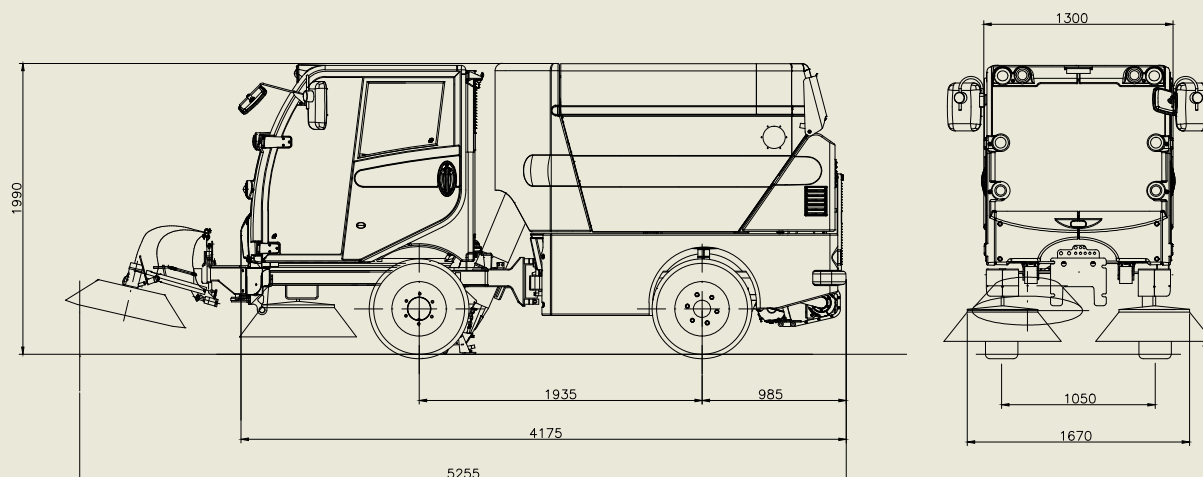

Dimensions

Length	4175 mm
Width	1300 mm
Height	1990 mm
Wheelbase	1935 mm
Track front/back	1050 / 1060 mm
Max. cleaning width Type XL	2660 mm
Max. cleaning width Type SL	2070 mm

Weight

Unladen weight	2950 kg
Payload	1550 kg
GVW	4500 kg

Tyres

215 / 70 R 15 C

Noise level

98 dB(A)

Drive system

Infinitely variable, hydrostatic drive with 2-speed, automatic load-dependent electronic control.

Driving Performance

Working speed	0-12 km/h
Travelling speed	0-50 km/h
Climbing ability up to	30%

Low emission 4 cylinder VM Euro 6c diesel Eng.

Typ	R754EU6C / R754ISE5 / D754TE3
Exhaust class	Euro 6c / Stage 5 / Stage 3 A
Displacement	2970 cm ³
Output	62 kW / 55 kW / 54 kW
Torque	270 Nm / 310 Nm / 255 Nm
Fuel Tank	70 lt
AdBlue Tank (Euro 6c)	14lt
Electrical system	12 V
Battery	100 Ah

CityCat 2020: the agile compact sweeper

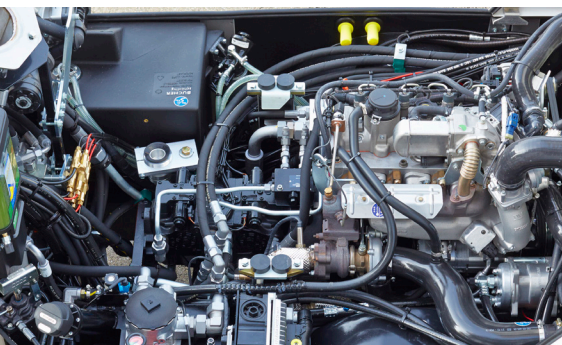

Low emission engine The smooth-running, economical Euro 6c diesel engine with controlled hydrostatic drive delivers all the power needed and ensures low fuel consumption and emission levels.

Articulated steering – maximum manoeuvrability Another advantage of articulated steering is increased manoeuvrability. With this system, the suction nozzle always faces in the direction of travel, giving a clean sweep without leaving unsightly dirt streaks behind.

Spring struts suspension (optional) Combined spring struts are available on request. They reduce vibrations in the cab by 30 percent and thus offer maximum driving comfort.

CityCat 2020 SL/XL Specifications

Chassis 2-piece steel frame welded from rectangular steel tubing. Articulated steering with torsion stabilisers. Suspension of both axles with leaf springs, in front additionally with shock absorbers.

Axles and steering Drive-axle at the front with differential and reduction gear. Hydrostatic controlled articulated steering.

Hydraulics Variable displacement axial piston pump for fan drive. Double gear pump for steering, auxiliary functions, side and front brush drive.

Brakes Hydraulic dual circuit braking system with disc brakes front and rear. Spring actuated parking brake acting on front axle with hand brake valve.

Cab Comfortably suspended sound insulated aluminium cab. Front screen in heat reflecting, curved, low reflection safety glass. Doors with electric windows. Variable heater, sun screens, screen wiper with washer. Fully adjustable comfort air suspension driver's seat. Adjustable steering wheel. Integrated working lights on the cab.

PSS (Programmable Sweeping System) Easy to survey and ergonomically arranged operating and monitoring instruments. CAN bus controlled PSS with coloured flat-screen monitor. Acoustic warning system for temperature and fluid level monitoring.

Pick-up system The wide, cast aluminium suction nozzle is suspended on a floating mechanism between the front wheels. Adjustable high performance suction fan.

Hopper
Stainless steel hopper, capacity 2.0 m³
hydraulic, tipping

Dumping height 1350 mm
Dumping width 1200 mm

Water system
Fresh water tank under cab ca. 300 lt
Recycling water in the hopper 130 lt

Electrically controlled water pump for water nozzles.

Brushes
2 side brushes left and right Ø 800 mm
Variable speed adjustment 0-150 U/min
Impactproof brush suspension

3rd front brush on Type XL for maximum cleaning width can be used left and right.

- Options**
- Air conditioning
 - Hydraulic lateral adjustment of side brushes
 - Wander hose
 - Weed brush
 - Water flushing bar
 - Snow plough
 - Snow roller brush
 - Roller spreader
 - High pressure water system
 - Combi Cab suspension

A range of optionals is available - Contact us for more information.

Subject to change without notice.

Bucher Municipal AG
Murzlenstrasse 80
CH-8166 Niederweningen
Tel. +41 44 857 22 11
Fax +41 44 857 24 10
sweepers@buchermunicipal.com
www.buchermunicipal.com/sweepers

simply great sweepers

Innovation • Competency • Reliability • Sustainability



Bucher Municipal E-Shop

