



User and Installation Manual RX35 - RX50 - RX65



Contents

1	Panel and control unit	6
2	Settings during operation	7
2.1	Display	7
2.2	Extra Hot Water	7
2.3	Temperature/Time	7
2.4	Setting temperature control	6
2.5	Control method OUT & IN (Factory Setting)	7
2.6	Control method OUT	8
2.7	Control method IN	8
2.8	Indoor Temperature with double heat curves	9
2.9	Restriction of electrical elements	9
2.10	Hot water temperature	10
2.11	Restriction of hot water temperature	10
2.12	Hot water priority	10
2.13	Min return temperature / Min inlet temperature	11
2.14	Holiday settings	11
2.15	Diode list	11
2.16	Fan control and timer	12
2.17	Smart control	13
2.18	Summer mode	13
2.19	Synchronization with solar panels	13
3	Maintenance	14
3.1	Main fuse	14
3.2	Replacement of air filter	14
3.3	Filter alarm reset	15
3.4	Checking the system pressure	16
3.5	Expansion vessel	17
3.6	Electronic galvanic anode	17
4	Component List	18
5	Installation	19
5.1	Transport and handling	19
5.2	Placement	19
5.3	Dimensions and outlet of ventilation connection	20
5.4	Dimensions and position of pipe connection RX35 / 50/65 High model	21
5.5	Dimensions and position of pipe connection RX35 / 50/65 - Low model	22
5.6	Pipe connections	23
5.7	Radiator system	23
5.8	Floor Heating System	23
5.9	Radiator and floor heating system	23
5.10	Connection without supply air unit (standard connection)	24
5.11	Connection with supply air units	24
5.12	Minimum circulation flow	24
5.13	Connection of extra hot water tank - High model	25
5.14	Connection of hot water tank - Low model	26
6	Ventilation connection	27
6.1	Silencing	27
6.2	Adjustment of ventilation	27
7	Electrical connection	28
7.1	Power supply 1x230V	28
7.2	Connection option 3x400V	28
8	Accessories / Additional equipment	29
8.1	Indoor temperature sensor / external room sensor	29
8.2	Connection of outdoor sensor	29
8.3	Connection of accessories	30
8.4	External alarm output (relay)	31
8.5	Accessories / Spare Parts	32
9	Commissioning	33
9.1	Re-filling the system	33

9.2	Venting the system	33
9.3	Venting of hot water tank	33
9.4	Draining / emptying the system	34
9.5	Emptying the heating circuit.	34
10	Adjusting the system.....	35
10.1	Adjustment of shunt groups	35
10.2	Adjustment of floor loops.....	35
10.3	Adjustment of radiators	35
11	Settings during installation.....	36
11.1	Basic Settings	36
11.2	Choice of regulation	37
11.3	Blocking of interfering resonances.	40
11.4	Maximum frequency of the compressor	40
11.5	Legionella elimination	41
11.6	Operation with heat elements only	41
11.7	Operation with fan off	41
11.8	Start-up and installation control.....	41
11.9	Adjustable HW overheating limit	41
11.10	Double Heat Curves.....	42
11.11	External mixing valve control.....	44
11.12	Synchronization with solar panels.	44
12	Troubleshooting.....	45
12.1	No heat to the elements (circulation water) although the compressor is running ...	45
12.2	The heat pump heats up the HW tank and then stops.....	45
12.3	Overheated auxiliary heater – smell of burnt rubber	45
12.4	Poor hot water capacity.....	45
12.5	The heat pump completely shuts down and does not start.....	46
12.6	Overheating protection cannot be restored.	46
13	Alarms.....	47
13.1	Filter Change Alarm	47
13.2	High Gas Pressure Alarm	47
13.3	Low pressure alarm 1.....	47
13.4	Low pressure alarm 2.....	47
13.5	Inverter alarm (0)	48
13.6	Heater overheat alarm	48
13.7	Hot water overheat alarm.....	49
13.8	Sensor fault TE0-TE2.....	49
13.9	Defrost alarm	50
13.10	Unknown HP box alarm	50
13.11	Heating overheat alarm.....	50
13.12	Heating limitation alarm.....	50
13.13	Heating return max alarm.....	50
13.14	SD memory card error.....	51
13.15	Inverter connection failure.....	51
13.16	Pressure ratio alarm.....	51
13.17	Hot gas temperature alarm	51
13.18	Alarm - Multiple alarms simultaneously	51
13.19	EEV min pos time out alarm.....	52
13.20	EEV Max pos timeout alarm.....	52
13.21	Clock not set alarm	52
13.22	Condenser temperature alarm	52
13.23	Room under heat alarm	52
13.24	Room overheat alarm.....	52
13.25	Defrost error alarm.....	53
13.26	Heating minimum alarm	53
13.27	Heating freez.danger alarm.....	53
13.28	Invalid controller type/version.....	53
13.29	PL1 input alarm.....	53
13.30	Sensor mismatch error TE1-TE2, TE2-TE5, TE1-TE5.....	53
13.31	No compressor function error.....	53
14	Pump Diagram.....	54
15	Fan Chart.....	55

16 System overview RX35 / RX50 / RX65 56
17 Wiring RX35/RX50/RX65 57
18 Connection terminals and fuses 58
 18.1 Connection to auxiliary heater X9 58
19 Components..... 59
20 CE declaration..... 61
21 Energy declaration 62
22 Technical data..... 63
23 Installation protocol 64

Preface

Thank you for choosing a ComfortZone heat pump. By reading this manual again, you will get the most out of your heat pump.

Keep the manual in the immediate vicinity of the heat pump as it is an important action in case of malfunction or alarm.

ComfortZone's heat pump is designed to maintain a long service life and achieve low outdoor temperatures. Comfort Zone heat pumps have been commercially available since 2003 and has given us a long and solid operating experience.

The warm indoor air is sucked from the wet rooms to the ComfortZone heat pump, where the heat is extracted and returned to the house as water-based heat. Extract air cooled to -15°C is sent out, new fresh indoor air is taken into the house via wall valves alternatively via a pre-heating air supply unit. The heat pump senses the

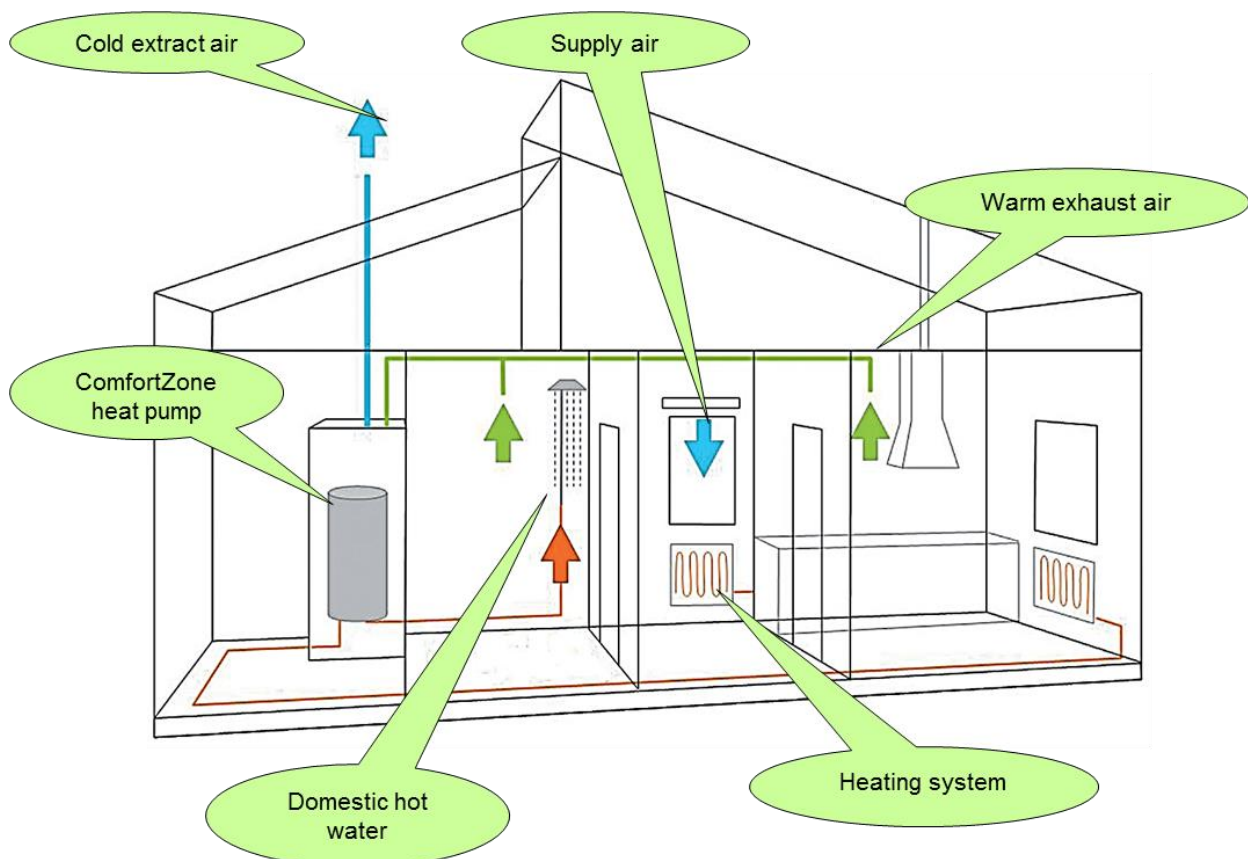

heat demand and works with a computer in a favorable manner so that the right amount of heat is sent to the house heating system.

The extract air heat pump also warms up hot water to a water tank, from which tap water is collected.

The effective ventilation gives you a very fresh indoor air. Moisture and contamination are vented and mould problems disappear.

Your installer sets the outdoor air heat pump for outdoor regulation, outdoor - & indoor regulation or indoor control only. You can fine tune the indoor temperature via the menu on the display.

Note:

In case of malfunction, first contact your supplier / installer for technical advice and action

1 Panel and control unit

The heat pump control unit is located on the front panel. From there, compressor, condenser, fan and other parts of the heat pump are controlled.

Use the push-button knob to set the desired room temperature, hot water temperature, hot water priority and other functions.

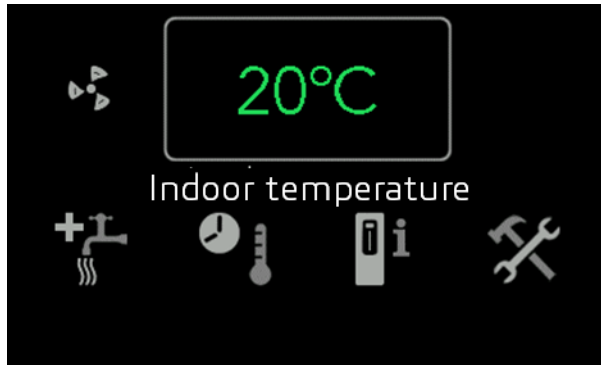

Fan setting	Extra hot water	Temperature / time	Operating info	Advanced settings
Fan Low Fan Normal Fan Boost	On/Off	Fine adjustment of indoor temperature	Statistics - Compressor energy - Additional energy	General settings Heating settings Fan setting
Weekdays		Hot water temp	- Compressor operating time	
Timer settings		Hot water priority Low – Normal – High	- Indoor temp. - Hot water production - Heat production	
Weekends		Min return temp		
Timer settings		Holiday reduction	Compressor freq. Compressor power Additional power	
			Operating mode Defrost	
			Heating	
			Hot water	

2 Settings during operation

2.1 Display

When the display is inactive, the background and icons are dimmed (invisible) and the indoor temperature is the only thing lit up.

Press or turn the dial, and the other icons will be activated. The icons are then lit, and a cursor frame with text shows the selected icon.

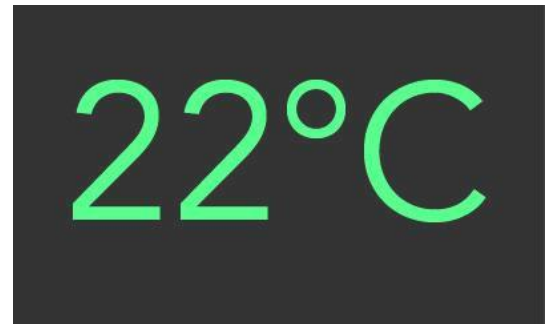

2.2 Extra Hot Water

The function is used for temporarily increased need for hot water.

Extra hot water is activated by pressing on the knob marked OK.

Icon changes appearance (begins to fill up a container).



Turn off by pressing the icon again. The function shuts off automatically after 3 hours.

2.3 Temperature/Time



Under the Temperature/Time icon you find:

- ⌘ Fine adjustment of indoor temperature
- ⌘ Hot water temp
- ⌘ Hot water priority, Low – Normal – High
- ⌘ Min return temp
- ⌘ Holiday reduction

2.3.1 Indoor temperature

Note: The adjustment of the heat control must always be carried out by the responsible and authorized installer.

This means that all of the housing surfaces and floors must have an indoor temperature corresponding to about 21° C when the heat pump is operating without regulation with the house's own thermostats.

If the residents want a higher or lower temperature, it is possible to adjust this according to their own wishes, see the next paragraph.

2.3.2 Uneven heat in the rooms

If uneven heat between floors, alternatively between different rooms occurs even though thermostats are fully open everywhere.

Uneven heat is due to the fact that the water flow in the heating system is not balanced, or that air is present in the system.

The problem is installation-technical.

Contact your installer.

2.4 Setting temperature control.

The ComfortZone RX35-50-65 can regulate the indoor temperature with various control methods, OUT & IN, OUT or IN.

Factory setting is OUT & IN.

Go to "Advanced settings" / Heating settings "and read which control method you are operating:

OUT & IN

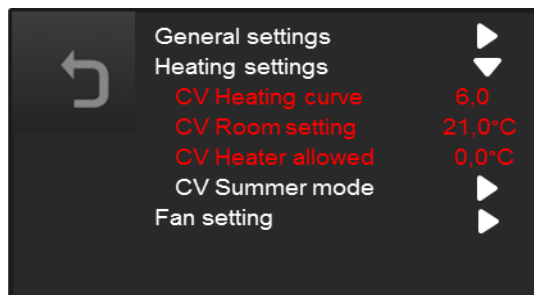

OUT

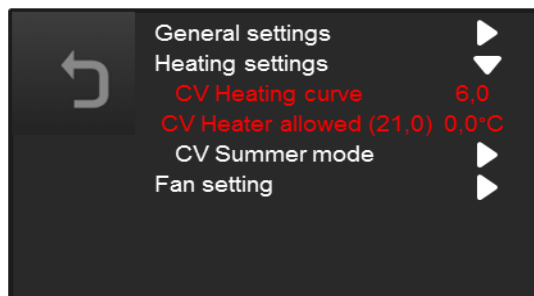

IN

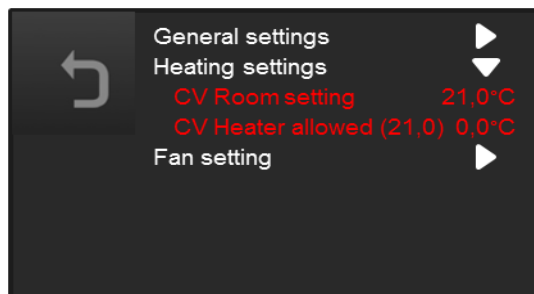

2.5 Control method OUT & IN (Factory Setting).

This option means that the outdoor temperature controls how hot circulation water is to be distributed in the house.

In this case, the indoor sensor acts to correct the temperature.

If the outdoor sensor fails to reach the desired indoor temperature, the indoor sensor will compensate by adjusting the heat, or reducing the heat.

Adjustment of heat with control method OUT or OUT & IN.

The issuer senses the outdoor temperature and sends hot circulating water into the housing at a temperature determined by a heating curve.

Heat curve 1.0 gives the lowest temperature and heating curve 10.0 maximum temperature.

The value can be selected to one decimal.

For mixed heating systems, i.e. underfloor heating and radiator heating the setting curve 5.0-6.0 is recommended. See section 14.1 "Choice of regulation".

Variations occur in different houses.

Before making a big adjustment, all thermostats in the housing must be set up to the maximum position, i.e. be fully open.

Problem:

Always too cold in the house: Increase the heating curve one step.

Always too hot in the house: Reduce the heating curve one step.

Never change more than one step in one day.

Allow the heat to adjust, preferably for 24 hours. When you experience a suitable temperature in your rooms, the curve has been adjusted and the adjustment is complete.

Reset thermostats in bedrooms to the desired position.

Always leave thermostats in rooms in maximum position i.e. be fully open.

Fine adjustment of heat with control method OUT or OUT & IN.

Although the heating curve is set correctly, it can feel cold indoors at certain outdoor temperatures.

To correct this problem, go to Temperature / Time and select Fine tuning temperature.



A menu as shown above appears. The bars represents different outdoor temperatures. Select the bar which is the temperature range you are most interested in adjusting and press the knob. Turn the knob up for increased indoor temperature and down for reduced temperature. First change is preferably done by turning up / down

the bar to half its length from the center line.
Save the set value by pressing the knob.

Now you have instructed the heat pump to increase / decrease the heating curve according to your preference based on the current outdoor temperature. The pump remembers the setting and adjusts the heating curve each time the current outdoor temperature is reached.
Fine-tune further if you are not satisfied.
Repeat the procedure at other outdoor temperatures / menu bars if necessary.

Note: If the heat pump's fine tuning is set so that all the bars are close to the max or min position, this means that the heat curve is incorrectly set. Increase or decrease the heat curve selection by one unit.

2.6 Control method OUT.

Means that the heating is controlled by the outdoor temperature only. The function is the same as with OUT & IN control but without indoor temperature compensation.



2.7 Control method IN.

Means that the heat pump is controlled by your indoor temperature only. You set your desired indoor temperature and the heat pump ensures that this temperature is reached.

With IN control method, the indoor temperature is controlled exclusively by the indoor temperature. Since the air comes from different places in the house, you have an average temperature from all of your exhaust air devices, or if the external indoor sensor is used, the temperature at where it is mounted.



The heat pump in this case is the entire house's thermostat. All room thermostats in accommodation rooms, i.e. living room, TV room, kitchen etc. shall have the thermostats set to maximum position, i.e. be fully open.

Thermostats for room temperature control should only be used in bedrooms.

Note! The function of the heat pump can be seriously disturbed if the indoor temperature is regulated by room thermostats in all rooms.

2.7.1 Problems that may arise.

Problems can arise with control method IN if the internal exhaust air sensor is disturbed by hot air coming through your ventilation system from heat sources such as a dryer, fireplace or sauna.

The heat pump becomes "tricked" and believes that the house is warmer than it really is.

If this is a problem, we recommend an external indoor sensor that is placed in a suitable place where it does not detect the hot air from the external heat sources, see section 2.11 below.

2.8 Indoor Temperature with double heat curves.

There is a possibility of two different heating zones being controlled via the heat pump. A function that is useful when heating the house with radiators and underfloor heating.

If double heat curves are used there is settings for CW Heating curve 2, CW Room setting 2 and CW Room factor 2 in the /Heating settings/ menu.

Zone 1 and zone 2 are adjustable individually.

Fine tuning of the temperature is common for zone 1 and zone 2.

For installation of double heat curves, see section 11.10.

2.9 Restriction of electrical elements.

The control board's automatic control of the indoor temperature can sometimes cause the electrical elements to be switched on even though the indoor temperature exceeds the set value. Allowing this provides the best temperature control, but can also cause some increase in power consumption.

To avoid this, the parameter "CW Heater allowed" is set to 0.0° C as the factory setting (default value).

The electrical elements are blocked if the indoor temperature exceeds the set value + 0.0° C, i.e. set value.

If " CW Heater allowed" is set " at -1.0° C, electrical elements are blocked if the indoor temperature exceeds set value -1.0° C.

The display shows also the absolute value, i.e. (Set indoor temp – CW Heater allowed.). In menu (If CW Room setting is 21°C):

"CW Heater allowed (20,0) -1.0°C "

If " CW Heater allowed " = IN is selected, the value is recommended to be -0.5° C.

Parameter " CW Heater allowed" can be found under "Advanced settings" / "Heating settings" / " CW Heater allowed ".

2.10 Hot water temperature



Set the desired temperature in the hot water tank. Higher temperature in the tank gives higher hot water capacity but increases heat losses.

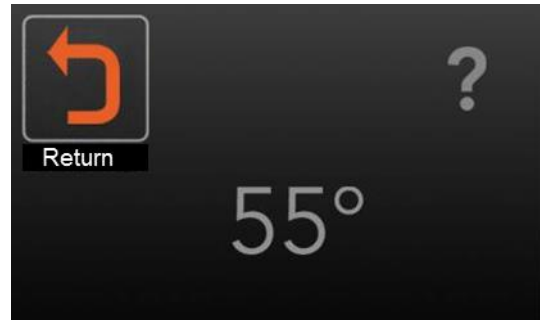

2.11 Restriction of hot water temperature

The models that have a built-in tank also have a mixing valve for limiting outgoing hot water temperature.

At delivery, the valve is at max, about 60° C, and the outgoing hot water temperature is the same as the tank temperature, i.e. set VV temp.

If you want to reduce the hot water temperature, without reducing the hot water capacity, turn the mixing valve, which is marked with an arrow, clockwise for lower temperature and counter-clockwise for higher temperature. Check the set water temperature at the tapping point closest to the valve. The hot water capacity is not affected by this limitation

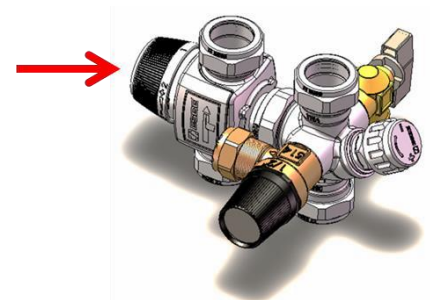

2.12 Hot water priority



Low priority - the compressor normally produces all hot water. Exceptions are made if the house is heated with the full power of the compressor, at the same time as the control unit indicates that hot water is to be produced.

Then the electricity supply is used to quickly reach the right hot water temperature.

Normal priority - hot water is primarily produced by the compressor, but if the hot water temperature drops too low, the electrical heater goes in to speed up the heating.

High priority - Same as normal priority, but the electrical heater is used sooner.

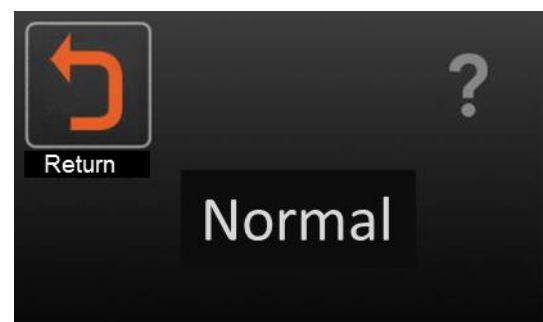

2.13 Min return temperature / Min inlet temperature



With this function one can keep a basic heat level in the circulation system even if there is no heating requirement in the house as a whole. Used when you want to have some heat even though the room temperature is above the set value.



2.14 Holiday settings



The holiday function lowers the house's indoor temperature by about 10 degrees during the number of days entered. One day before the end of the holiday period, the house starts to warm up. If there is a heating requirement, the compressor starts up and runs for 12 hours. If the indoor temperature has not reached the desired value, the additional heat is used so that the house has the desired room temperature.

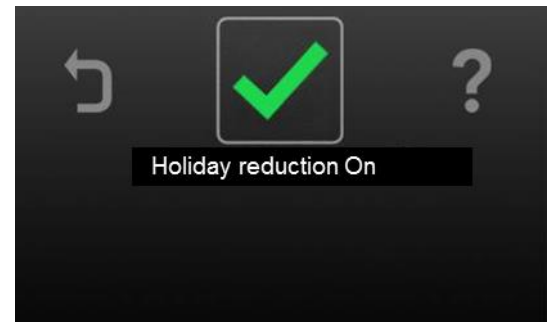

2.15 Diode list

The green diode list can be adjusted in brightness or turned off completely. Go to "Advanced settings" / "General settings" / "LED list function" 0 = LED list off, 1-6 LED list brightness.

2.16 Fan control and timer.

The fan speed can be set to Low, Normal, High and Timer mode.

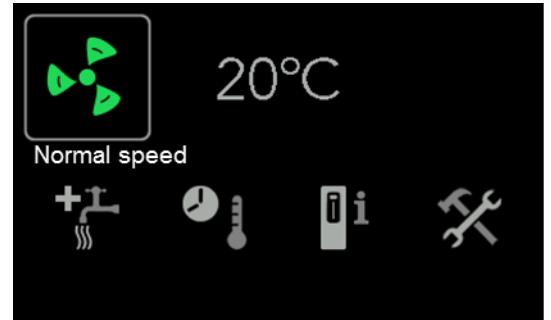

In the timer function you can choose to reduce the fan speed for weekdays or weekends. Meaning that the fan speed is reduced to LOW during set time.

Timer setting for weekdays is shown with the first 5 bars in red indicating Monday to Friday.

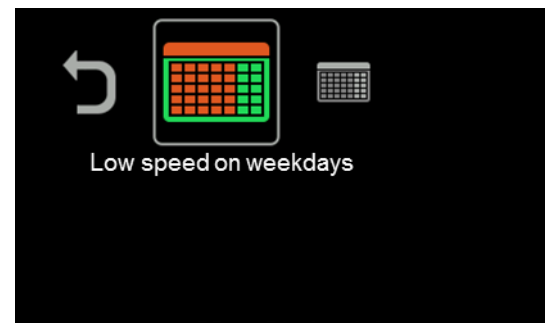

Timer setting for weekends is shown with the 2 last bars in red indicating Saturday and Sunday.

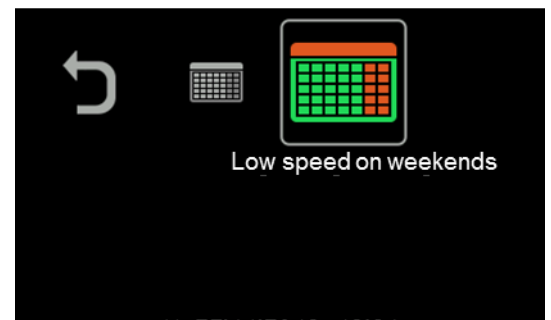

For both of these functions, you will enter the start and stop time.

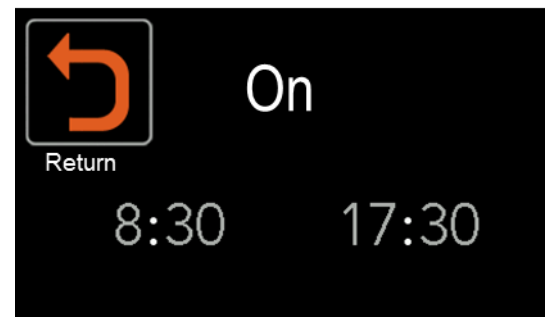

2.17 Smart control

To reduce the energy used for HW production the smart control function may be used. Go to "Advanced settings" / "General settings" / "Hot water settings" / "Smart control" / "Smart control" / Set to On.

The temperature in the HW tank will be reduced during periods when HW consumption usually is low in your household. During peak hours the temperature will still be the set HW temp value.

2.18 Summer mode

Summer mode is used when you want to avoid unnecessary heating at night during periods of hot days and cool nights.

The function requires selecting the "OUT" or "OUT & IN" control method. The function is not possible in the control method "IN".

Function "UV Summer Mode" = Off:

The control unit is in normal mode and the heating is controlled in the usual way.

2.18.1 Setting "UV Summer Mode".

Go to "Advanced settings" / "Heating settings" / "UV Summer mode": Change OFF to **Auto**.

2.18.2 Function "UV Summer Mode" = Auto:

When the outdoor temperature is higher than "Outdoor temp. limit" (18.0° C) for longer time than what is stated on parameter "UV Min heat" (8.0h), the controller automatically controls the minimum heating.

When the outdoor temperature is lower than "Outdoor temp. limit" (18° C) for a longer time than what is stated on parameter "UV Norm" (12.0h), the control unit automatically controls the normal mode.

At minimum heating, the flow temperature is controlled according to parameter "UV Min inlet temp" (18° C), which is shown under the menu "UV Other" / "UV Min inlet flow".



2.19 Synchronization with solar panels

If the "Synchronization with solar panels" option is installed, a value is added under "Operating information" in the display, Solar power.

3 Maintenance

3.1 Main fuse

The automatic circuit breaker functions as the main switch. The automatic fuse is located behind the front panel to the right. Normally, the circuit breaker should not be switched off. When the exhaust air heat pump is in operation and main power is on, the green diode list lights up on the front panel in strength 1-6, function set in 0 mode does not illuminate the LED list.

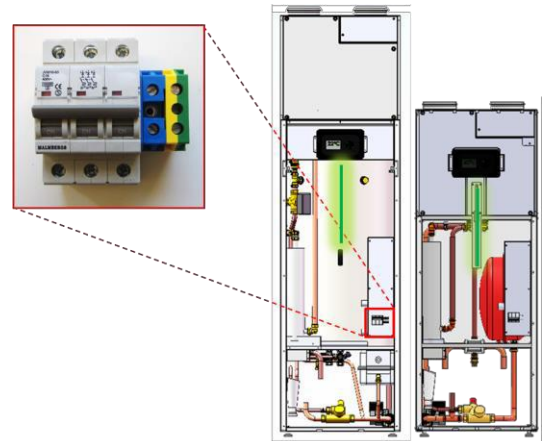

3.2 Replacement of air filter

The air filter must be changed / cleaned regularly. When it is time to check/clean (every 3/6/9 months) or change (every 12 months) the filter, a symbol for the filter and the text "filter change" appears on the display.

New air filters can be purchased from your dealer.

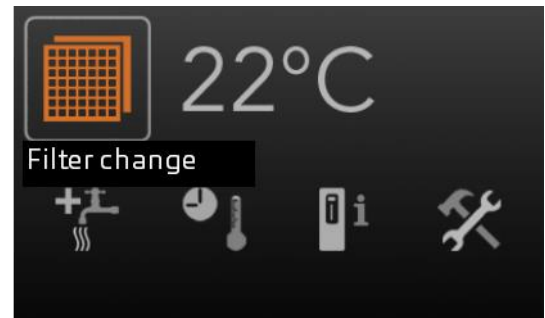

Changing of the air filter is easiest done by: Removing the front panel. Then turn off the main switch. Unscrew the filter cover screws. Remove the filter cover. Pull out the filter and clean or change to a new filter. Replace the filter cover and tighten the screws. Turn on the main power switch. Replace the large front cover.

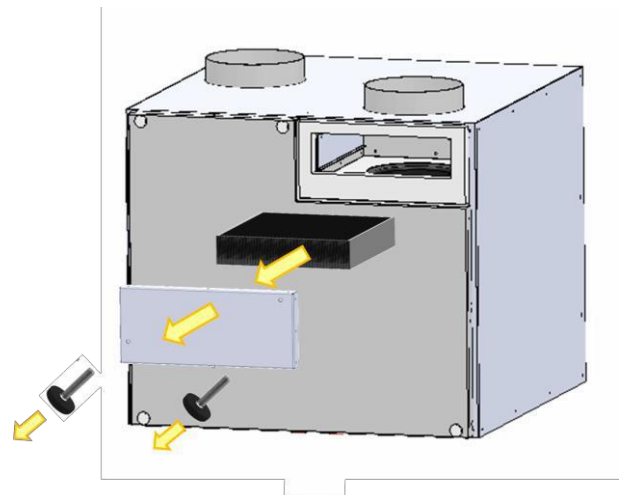

The filter is most easily cleaned with a vacuum cleaner. We recommend that you change to a brand-new filter at least once a year.

In connection with the replacement / cleaning of the air filter, control the system pressure according to section 3.4.

3.3 Filter alarm reset

The bar for the filter symbol is located in the upper left corner.
Press the OK button.

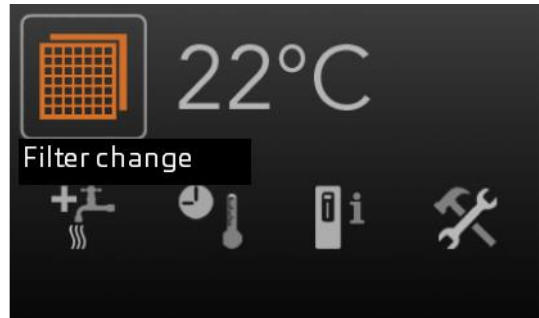

The text "Exhaust air filter needs to be replaced" appears on the display.
Turn the marker to the gray check mark, the check mark changes color to green symbol.

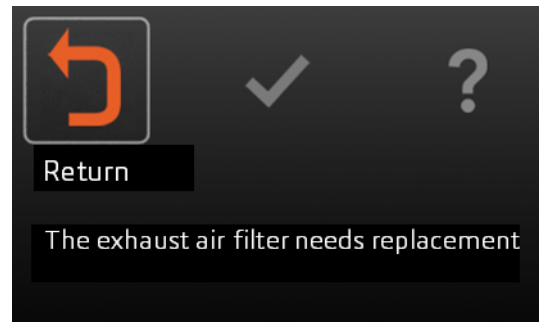

The text "Filter changed" + "The exhaust air filter needs to be replaced" appears on the display.
If the filter is changed, press the OK button.

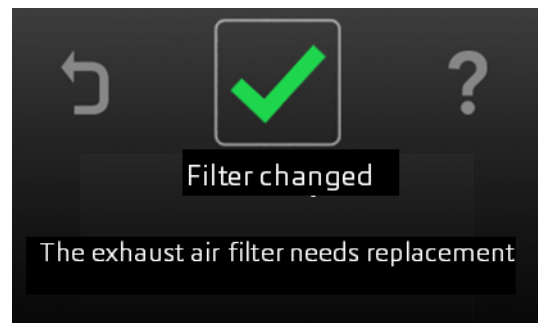

The text "Is the filter really filter changed?"
Appears on the display.
If the filter is changed, press the OK button.
The filter alarm is now reset.

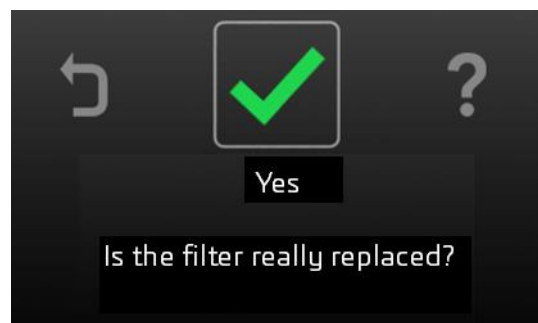

3.4 Checking the system pressure

The system pressure needs to be checked and the water system needs to be replenished from time to time, because the air pockets that were initially in the system are transported around and gradually emptied out. The first few days after installation, the pressure should be checked daily.

- Adapt to the habit of always checking the pressure at least every time the air filter is changed or cleaned and each time the radiators or floor heating coils are aerated.

3.4.1 High model:

- Remove the large front cover.
- Check the pressure, the black indicator on the manometer (1) should show 1.0-1.5 bar.
- If necessary, open the filling valves (2 and 3).
- Close both filling valves when the pressure gauge shows desired value.
- Put the front cover in place.

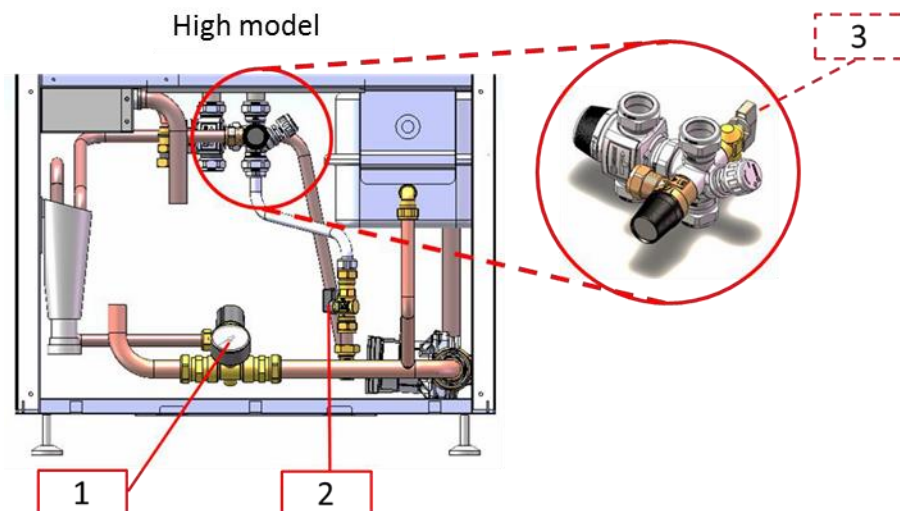

3.4.2 Low model:

- Remove the front cover.
- Check the pressure, the black indicator on the manometer should show 1,0-1,5 bar.
- If necessary, open the filling valve (which is mounted by your installer, and is normally located at the hot water tank)
- Close both filling valves when the pressure gauge shows desired value.
- Put the front cover in place.



3.5 Expansion vessel

In the circulation system there is an expansion vessel which must be air-filled (so-called pre-pressure). RX35 / 50 / 65H, HIGH model should have a prepress of 1.0 Bar. RX35 / 50 / 65L, LOW model should have a prepress of 1.0 bar.

3.6 Electronic galvanic anode

An electronic galvanic anode is mounted in the tank.

Function control can be performed by loosening the control panel front panel and checking that the green lamp inside the plate is lit green. (see the black arrow)

If the green light is not lit, contact your service representative.

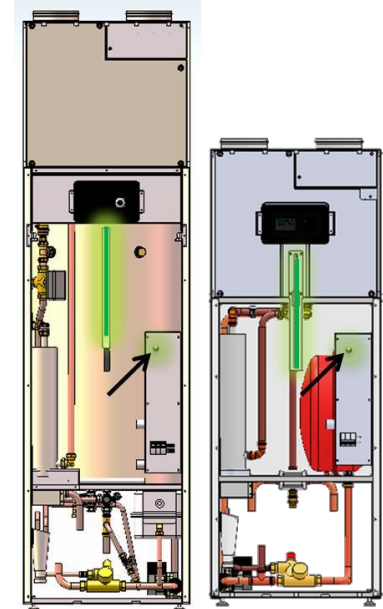

4 Component List

These images show the important components in the heat pump.

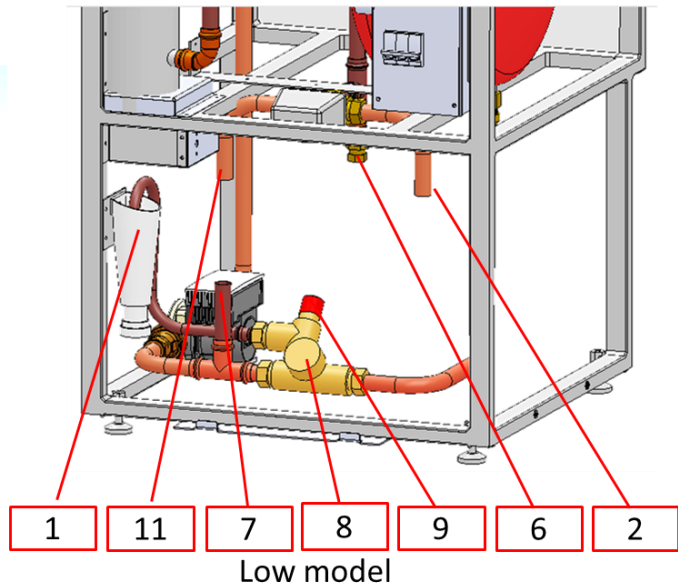
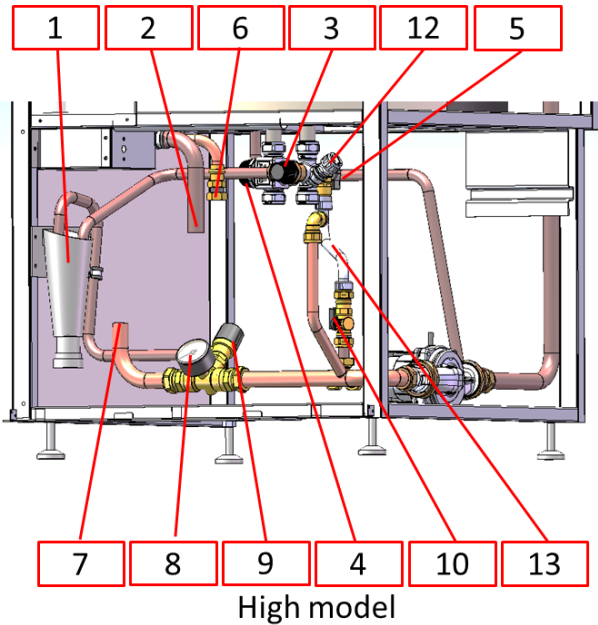

1. Waste water funnel, shall be connected to floor drain.
2. Connection hot water tank.
3. Safety valve (10 Bar) for incoming water.
4. Mixing valve, temperature limiter of domestic hot water
5. Filling valve / drain
6. Connection supply line for supply air units.
7. Connection of return water from circulation water and possibly air supply units, low model also returns from hot water tank.
8. Pressure gauge for system.
9. Safety valve (2.5 Bar) for tank and circulation water (system pressure).
10. Filling / drain valve.
11. Connection supply line for circulation water to the house.
12. Shut-off valve
13. Filler / drain hose

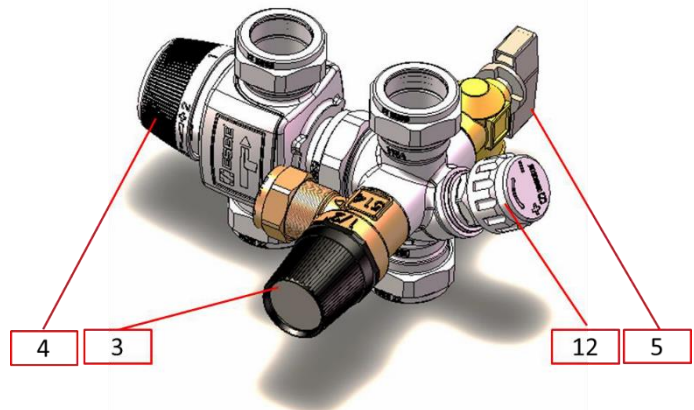

5 Installation

5.1 Transport and handling

The ComfortZone RX35 / RX50 / RX65 must always be transported standing. It should always be stored in a dry and frost-free space.

The heat pump contains refrigerant and should therefore be handled with the utmost care to minimize the risk of leakage.

5.2 Placement

The heat pump must be placed in a wet room with a floor drain in the event of a leak. The heat pump is preferably placed on the ground floor next to the outer wall or a well insulated partition wall. The heat pump should not be placed against the bedroom wall.

If the heat pump is placed upstairs or on wooden beams, sound insulation must be performed extra carefully, vibrated rubber feet are recommended (included in the delivery).

The walls of the installation space shall have double plaster boards on both sides and shall be completely filled with rock wool, or have corresponding sound insulation, i. $R'w = 44$ dB.

The ceiling of the installation room shall have the structure insulated with stone wool to full thickness.

The heat pump should be free, with a distance of at least 10 mm from the wall and other fixed furnishing.

If the upper cabinet is mounted, this must have at least 2 mm air gap for the ceiling or other fixed fittings.

Minimum ceiling height of 2350 mm is required for the ventilation connection. To raise the heat pump to a standing position, 2200 mm is required.

There must be a free space of 800 mm in front of the machine for service and maintenance, when placed in corner 1000 mm.

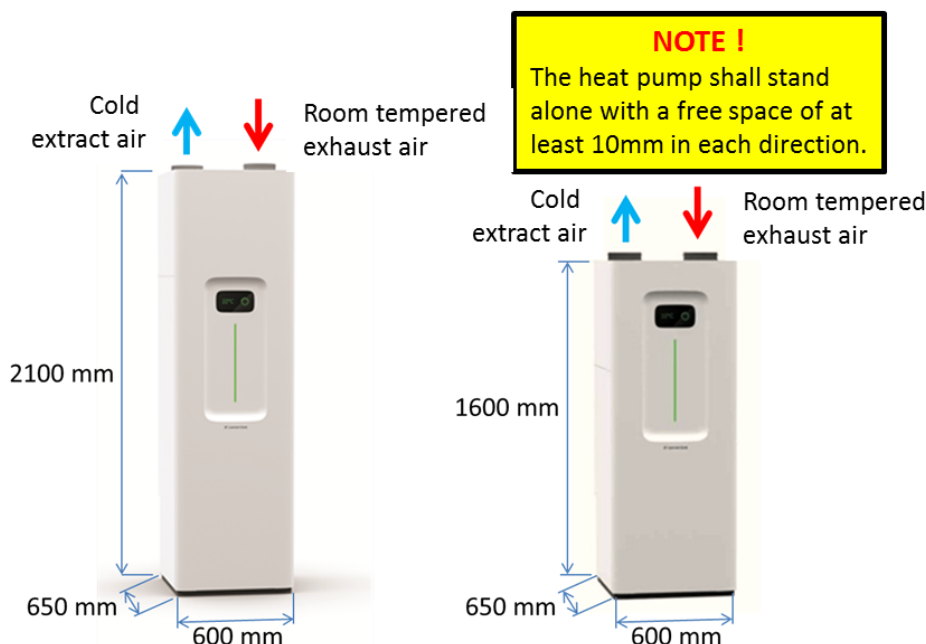

5.3 Dimensions and outlet of ventilation connection

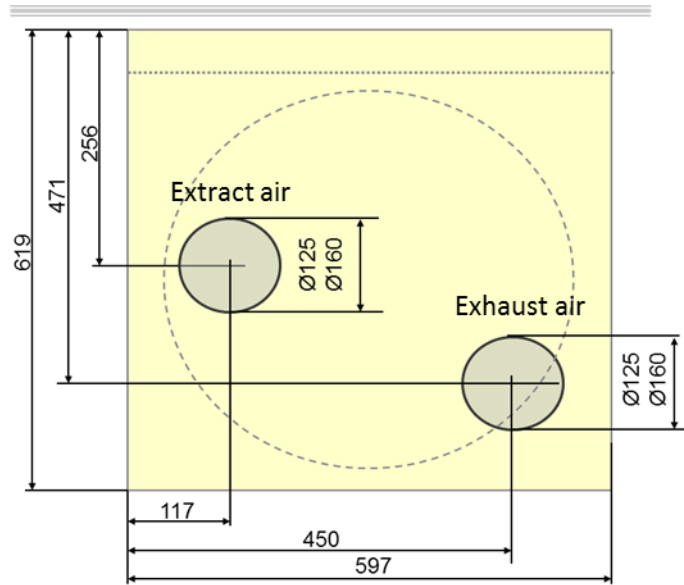

5.3.1 Ventilation tube dimensions

	RX35	RX50	RX65
Exhaust tube Ø	125 mm	125 mm	160 mm
Extract tube Ø	125 mm	125 mm	160 mm

NOTE:

The heat pump must be connected to ventilation ducts equipped with duct silencers.

See section 8. Ventilation connection.



5.4 Dimensions and position of pipe connection RX35 / 50/65 High model.

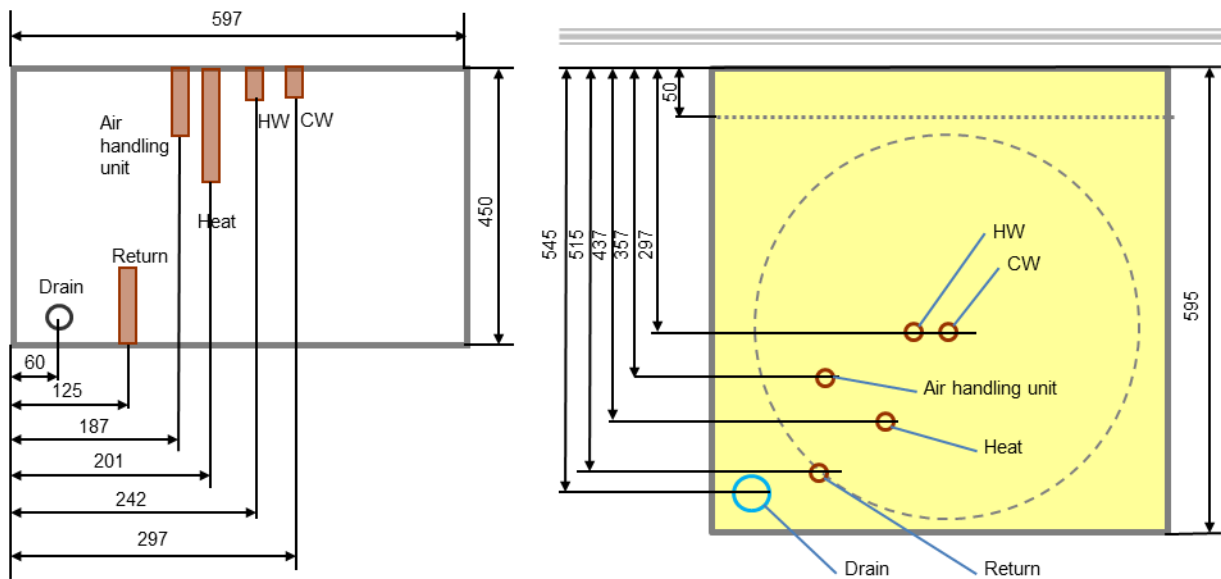

5.4.1 Pipe dimensions

Heat	Flow pipe, circulation water	Pipe Ø 22 mm
Return	Return pipe, circulation water	Pipe Ø 22 mm
CW	Connection cold water	Compression Ø 22 mm
HW	Connection hot water	Compression Ø 22 mm
Air handling unit	Connection of air supply units, plugged in	External screw DN15
Drain	Drain water discharge	PVC pipes 32 mm, ex M42x2

RX-35-50-65 High model

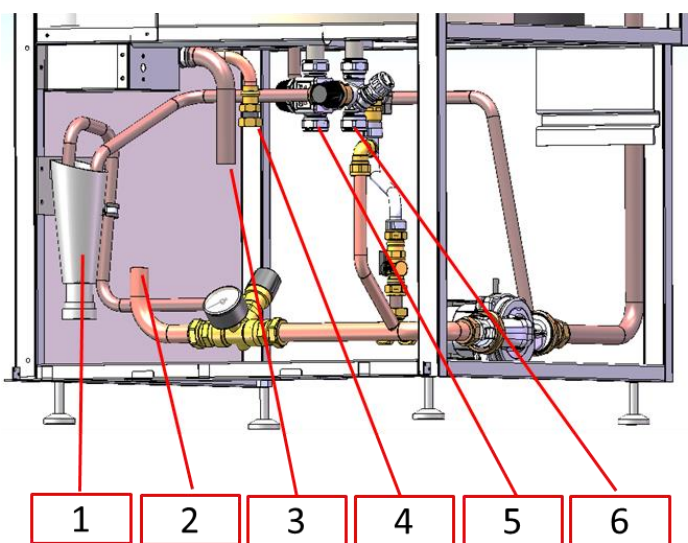

1. Drain water, connected to floor drain.
2. Return from the house and possibly air supply units.
3. Supply of circulation water to the house.
4. Connection for air supply units, optional.
5. Hot tap water.
6. Incoming cold water.

5.5 Dimensions and position of pipe connection RX35 / 50/65 - Low model.

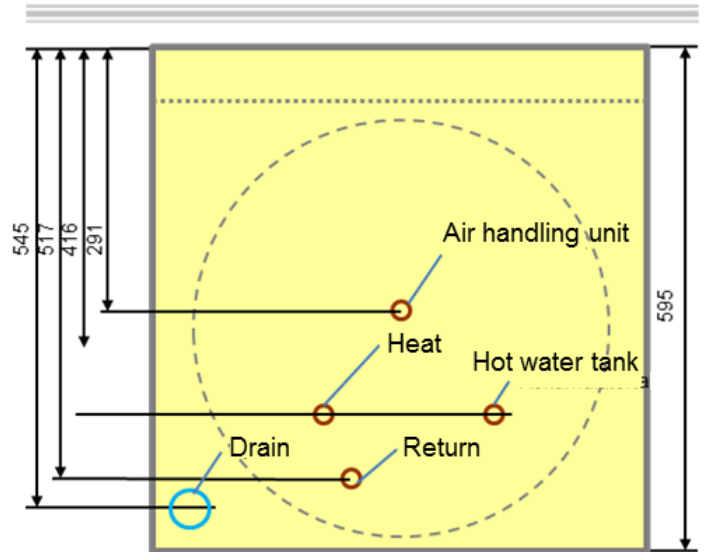
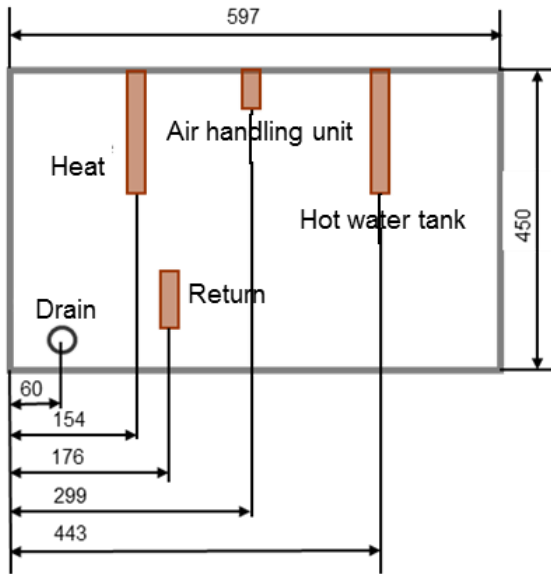

Pipe dimensions

Heat	Flow pipe, circulation water	Pipe Ø 22 mm
Return	Return pipe, circulation water	Pipe Ø 22 mm
Hot water tank	Connection hot water tank	Compression Ø 22 mm
Air handling unit	Connection of air supply units, plugged in on delivery, optional	External screw DN15
Drain	Drain water discharge	PVC pipes 32 mm, ex M42x2

Pipe connections

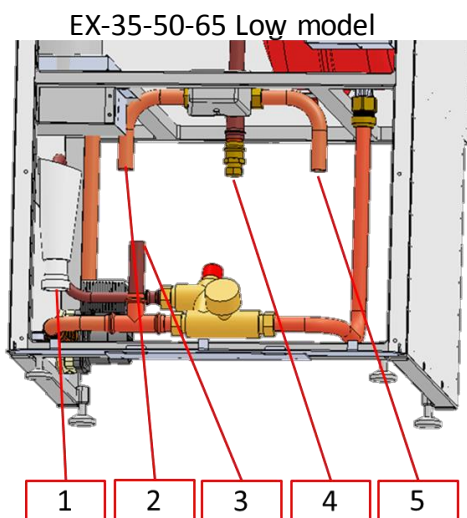

1. Drain water, connected to floor drain.
2. Heat circulation water to the house.
3. Return from the house, hot water tank and optionally air supply unit.
4. Connection for air supply units, optional.
5. Supply for hot water tank.

5.6 Pipe connections

To avoid noise in water pipes, all pipes must be connected with flexible hoses.

All pipes and hoses throughout the heating system must be of diffusion-tight design.

Both old and new pipe system must be properly cleaned before the heat pump is connected so that any impurities do not damage the heat pump.

When installing to an old system it is especially important that the system is cleaned.

We recommend that a dirt filter is mounted on the return pipe and preferably a filter-fitted ball valve according to the picture above.

If there are high levels of magnetite particles in the circulating water (black circulation water), a magnetite filter should also be installed.

Note that the product warranty does not cover damage caused by dirt or contaminants in the heating system.

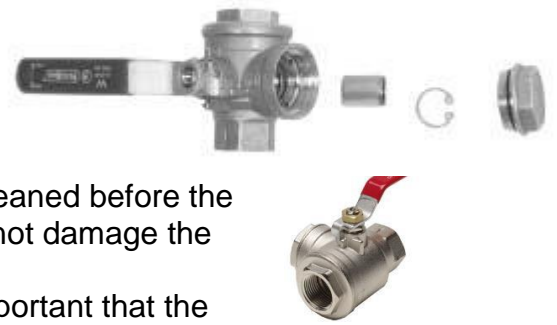

5.7 Radiator system

The radiator system must be dimensioned so that the supply temperature does not exceed 60° C.

If not, the radiator system must be modified or supplemented with additional radiators.

5.8 Floor Heating System

The circulation pump capacity is stated under the heading Pump Diagram (section 19) and in Technical Data (section 24).

The built-in circulation pump is usually sufficient for most floor heating systems.

5.9 Radiator and floor heating system

If part of the house have radiators and part have underfloor heating, the radiator part must be connected directly to the heat pump. The floor heating system must be connected via a separate shunt group with its own circulation pump.

Exceptions can be made in the event that the radiators are so dimensioned that they can function with the same supply temperatures as the floor part.

In this case, the radiator part and the floor part must be connected in parallel directly to the heat pump.

There are two different heating zones that can be controlled via the heat pump. A function that is useful when heating the house with both radiators and underfloor heating.

See section 14.9.

5.10 Connection without supply air unit (standard connection)

If supply air unit is not used, please leave <air handling unit> untouched.

5.11 Connection with supply air units

The RX35 / RX50 / RX65 has a separate connection for air supply units to ensure circulation regardless of the gear valve position.

The air supply unit must be equipped with a thermostatic valve controlled by the supply air temperature. The set air temperature must never exceed 20° C.

When ComfortZone's air supply unit T12 is installed together with the ComfortZone exhaust air heat pumps RX35 / RX50 / RX65, this is installed according to the enclosed installation manual.

Air supply units T12 are controlled via the control unit in ComfortZone's exhaust air heat pump.

The air supply unit is connected with 15 mm pipes. The return line is connected to the pipe marked <circ return>.

5.12 Minimum circulation flow

The heat pump's circulation water flow must be at least 6 l / min (RX35), 8 l / min (RX50) and 10 l / min (RX65) at maximum heat output.

A minimum flow of 3 l / min must always be ensured.

If it is not possible to ensure the circulation water flow as described above, an overflow valve or pressure-controlled bypass must be mounted on the circulation water circuit, which opens when the pressure drop across the circulation water circuit becomes too large. The user then has the possibility to regulate the heat with thermostats without risking too much restriction of the flow.

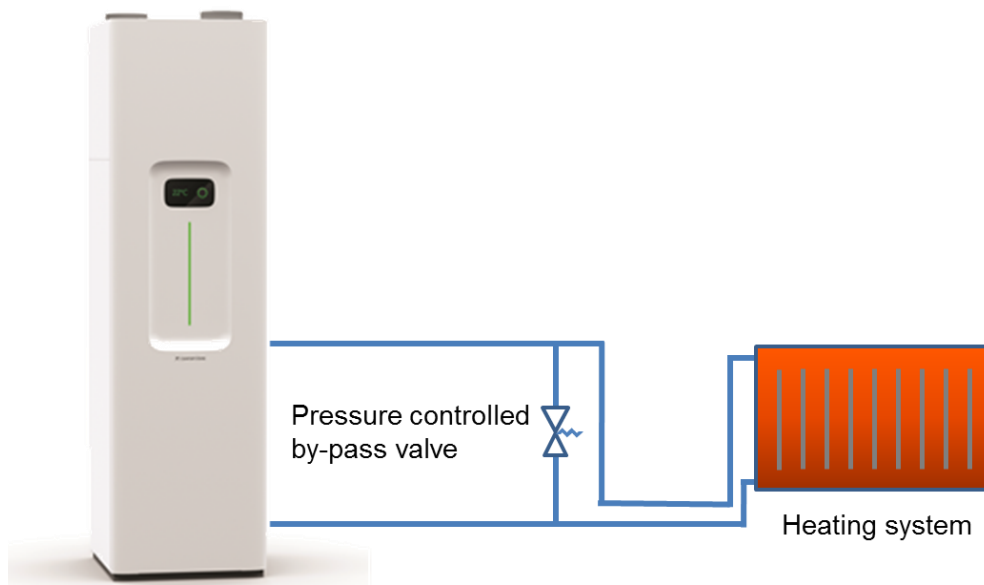

5.13 Connection of extra hot water tank - High model

An extra water tank with loop controller or storage tank, without its own electric heater, can be connected to the heat pump to increase the total hot water capacity.

RX35 / 50/65 High model. Remove return pipe.

(A) from the T-coupling. Connect the return (Blue) from the hot water tank, outlet 1 with 22 mm pipes and connect with suitable couplings (with transition 15-22 mm) to the T-coupling (B). water capacity.

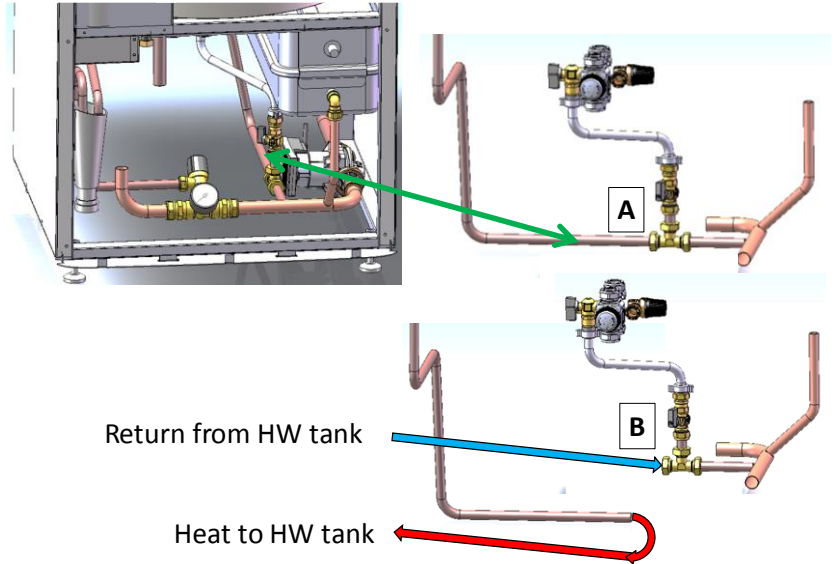

The heat to the hot water tank (Red) is connected with 22 mm pipes and suitable clamping ring connections (with transition 15-22 mm) to the hot water tank, outlet 2.

The following instructions and outline diagrams show the connection of the Borö hot water tank "Tida".

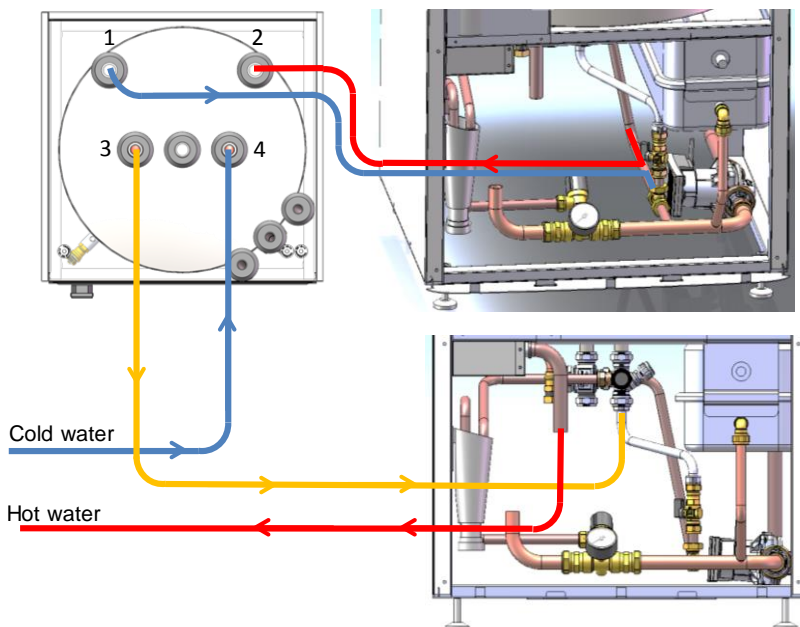

Fresh cold water connects to the connection (4) on the "Tida" tank. Outgoing hot water (3) from the "Tida" tank is connected as heated hot water with 22 mm pipes to the heat pump's normal cold water connection.

5.14 Connection of hot water tank - Low model

RX35 / 50/65 Low model.

Connect return pipe (1) and supply pipe (2) between heat pump and tank as shown. Connect the incoming CW = cold water (3) and HW = hot water (4) to the hot water tank as shown.

A crane (5) for filling the circulation system must be mounted in connection with the hot water tank.

Filling the circulation system should be carried out with hot water.

Sensor TE24 (6) is mounted in the hot water tank immersion pipe or electricity. The sensor is properly fixed and heat-insulated from ambient room air.

The sensor is connected to the control unit, terminal block X4, terminals 5 and 6.

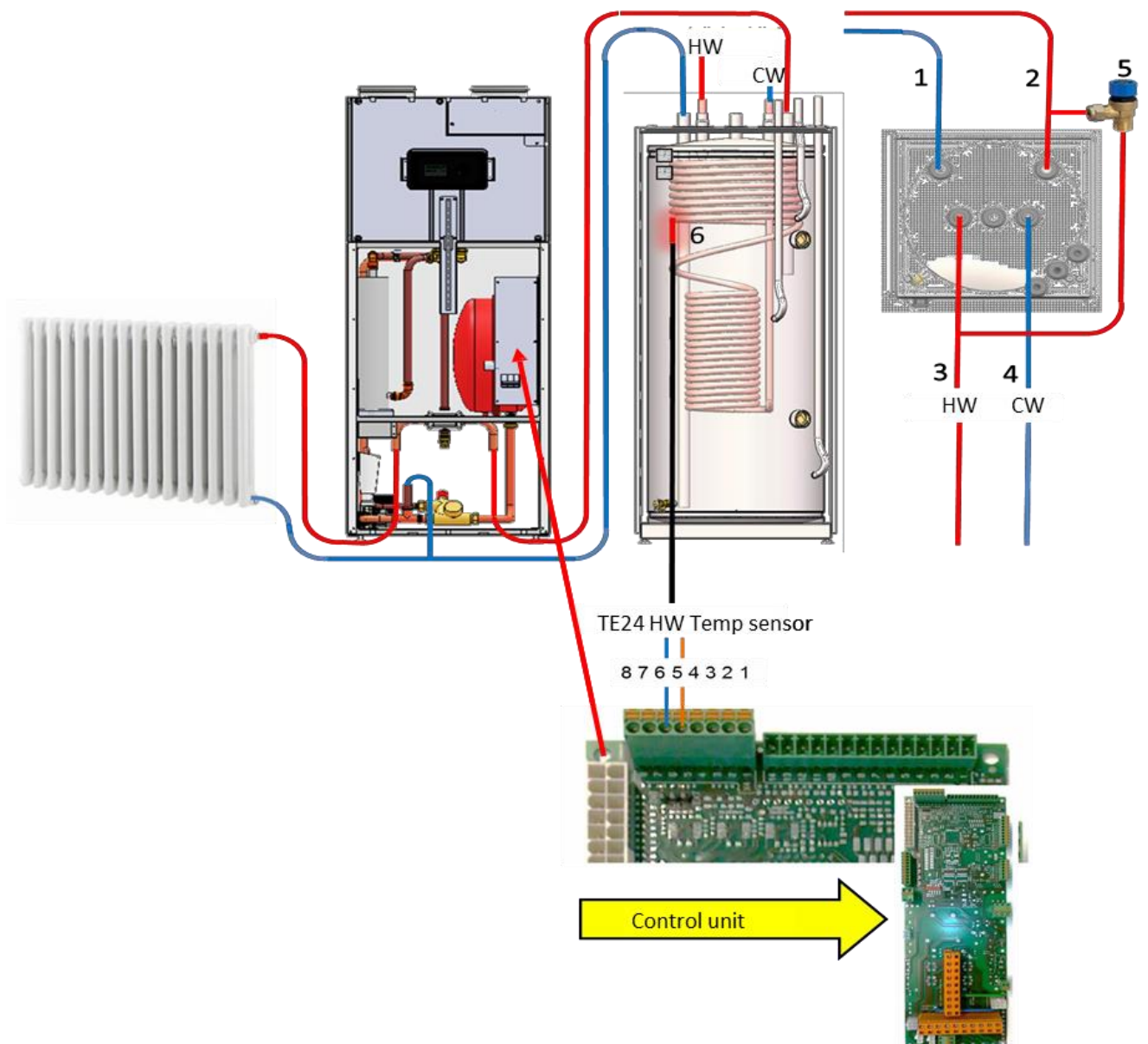

6 Ventilation connection

The heat pump is connected to the exhaust and extract air ducts with flexible air hoses that are extended and freely mounted so that no sharp creases or bends occur.

After installation, ensure that the air hoses are truly flexible so that no vibrations can be transmitted to the housing.

The duct system shall be of the lowest density class B. The entire extract duct shall be diffusion-tight and insulated with at least 50 mm mineral wool, 19 mm "Armaflex" or equivalent.

The extract air duct must be pulled so that any condensation water can flow back to the heat pump without water accumulation occurring.

6.1 Silencing

To achieve the lowest noise level, the ventilation system must be equipped with duct silencers.

6.2 Adjustment of ventilation

For the RX35 / RX50 / RX65 the fan power is set via the display. This is done in the menu "Advanced settings" see section **14 "Installation settings"**.

If the air supply unit T12 is used, its fan strength is also set in the same menu.

It is extremely important that the supply air flow is lower than the exhaust air flow, otherwise you risk moisture damage and greatly increased heat consumption. Factory setting of -30% for "T12 supply air fan core" corresponds to about -10% in supply air flow in relation to exhaust air flow.

The ventilation flow is determined by the ventilation needs of the house. Too low airflow gives a poorer indoor climate. Too high airflow result in greater ventilation losses and more operating costs.

In order to obtain sufficient air exchange in each room the devices need to be properly positioned and adjusted.

The exhaust air flow should not be less than 100 m³ / h for RX35, 150 m³ / h for RX50 and 220 m³ / h for RX65 for the heat pump to function properly.

The adjustment must be made by a specialist and a protocol must be drawn up.

7 Electrical connection

7.1 Power supply 1x230V

Connect 230 V (1-phase + N + PE) to main switch / main fuse.

The main circuit breaker / main fuse is located inside the front large front cover.

The cover is unscrewed and the incoming phases are connected to the main switch as shown in the figure below.

NOTE: The main switch / main fuse must never be set to the on position unless the entire system is water-filled, vented and with the correct system pressure.

When the main switch / main fuse is switched on, the green light bar on the front panel illuminates.

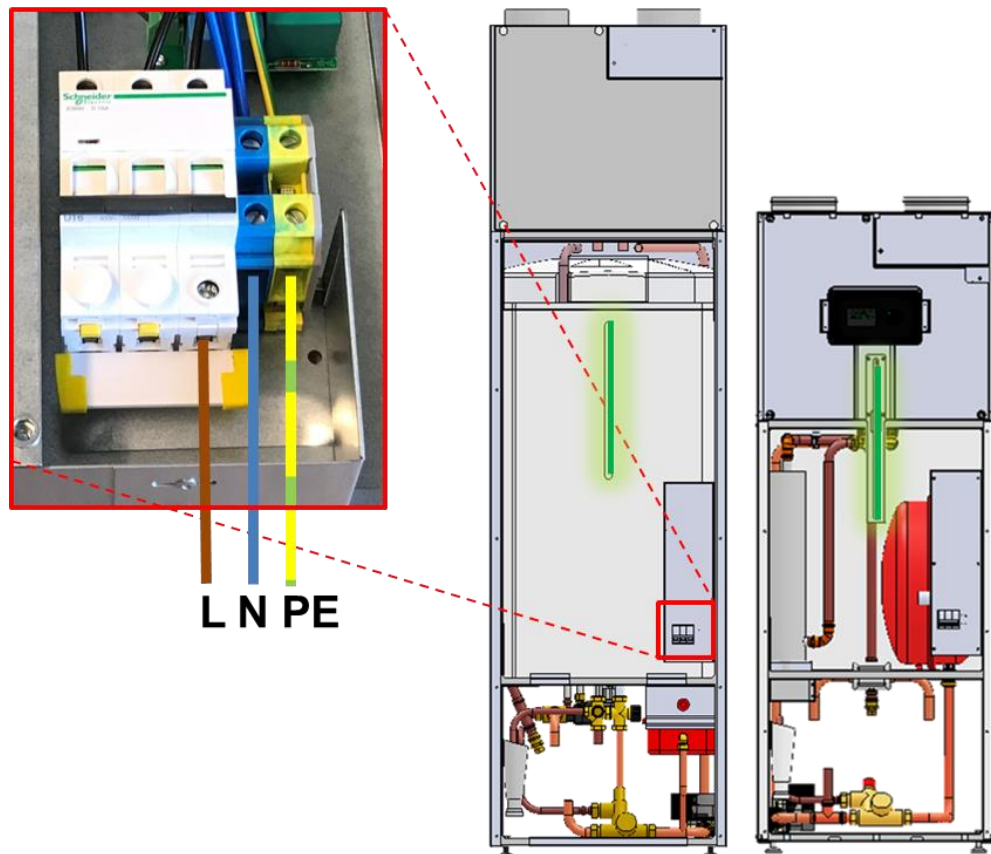

7.2 Connection option 3x400V

The unit may be also connected to 3x400V + N + PE.

In that case the jumper between the three phase connections and the screw caps shall be removed and three phases connected on the main circuit breaker. Phases may be connected in any order without affecting the function.

8 Accessories / Additional equipment

8.1 Indoor temperature sensor / external room sensor

The heat pump's temperature sensor for indoor temperature is already connected and is fixedly mounted inside the heat pump's exhaust air duct.

External room temperature sensor for the indoor temperature can be mounted, it is connected to the control board on terminal block X4, terminals 3 and 4. **NOTE! Reverse numbering! Terminal 1 at the far right!**

The jumper mounted on terminal J1 is moved from terminal 1-2 to 2-3.

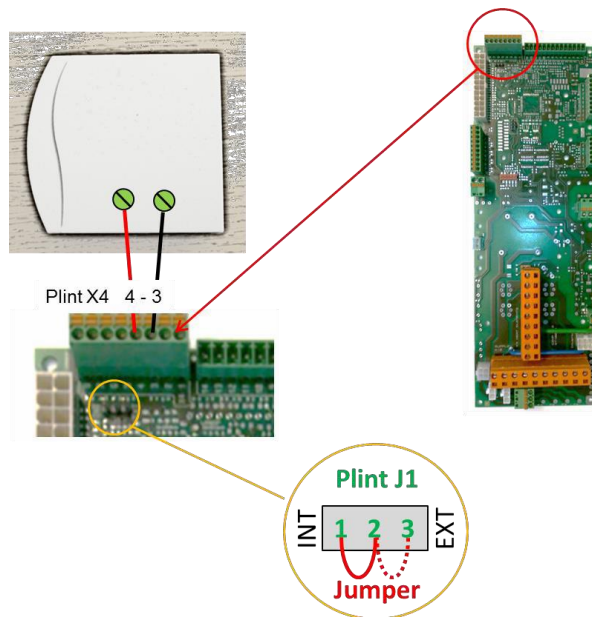

8.2 Connection of outdoor sensor

When using indoor & outdoor sensors (factory setting) or outdoor control, outdoor sensors must be fitted. Outdoor sensors must be mounted in a suitable location, preferably on the northern facade of the house.

Outdoor sensor is connected to terminal block X4, socket 1 and 2.

NOTE! Reverse numbering! Terminal 1 at the far right!

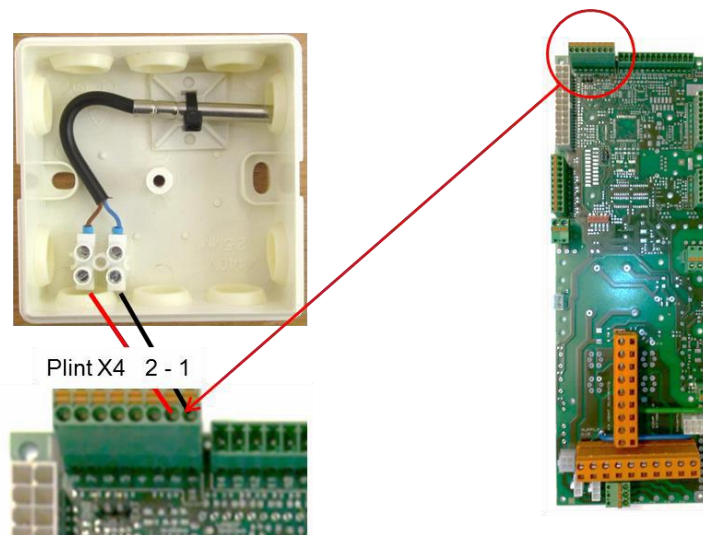

8.3 Connection of accessories.

Fan control for air supply units T12 is used when the house is equipped with ComfortZone supply air unit T12. Allows to control the heat pump fan and the supply air fan assembly together.

Connects to terminal block X3, brown conductor to pin 1 and blue conductor to pin 2.

Fireplace switch is used to prevent smoke when a fireplace is lit, a push of the button stops exhaust fan for 5 minutes (adjustable).

Connected to terminal block X3, terminals 3 and 4

Fan effect, low - normal - boost is used to regulate the ventilation in the house with a switch which is connected to Plint X3, terminals 5-6-7.

The fan effect can also be easily controlled on the display unit.

Boost = (placement 6-7) The fan effect increases by 30% from normal value.

Normal = basic setting for the heat pump.

Low = (placement 5-6) reduction of fan power by 30% from normal value.

NOTE! Reverse numbering! Terminal 1 at the far right!

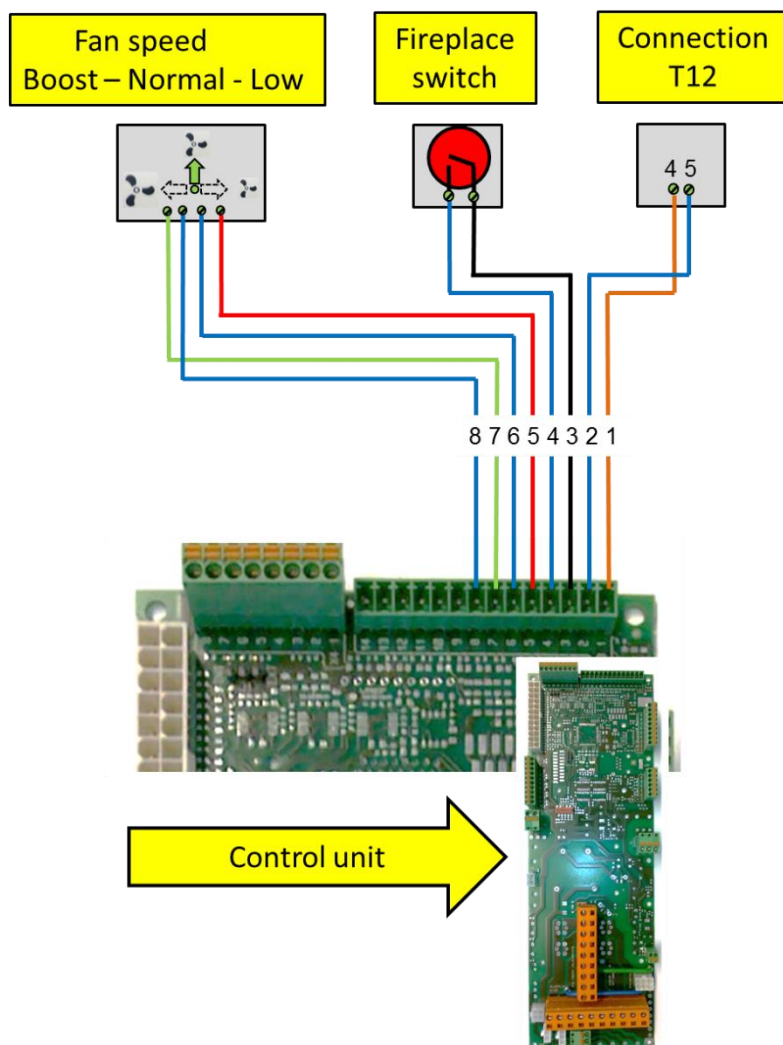

8.4 External alarm output (relay)

An alarm can be connected via the external relay connection; a sound signal, lamp or the like that warns if the heat pump is in alarmed position. The alarm relay has a changing function. When the alarm is not active (no alarm), NC-COM is closed and NO-COM is broken. Here you choose which function is best suited for the external alarm you want to use.

Max load 230V / 2.0A

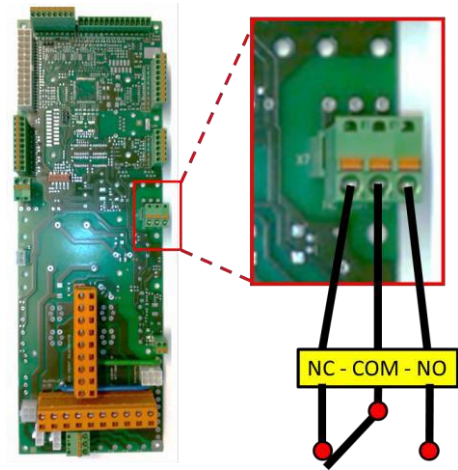

8.5 Accessories / Spare Parts

8.5.1 External indoor sensor.

An external indoor sensor is available as an accessory for wall mounting.

The heat pump can be disturbed by foreign heat sources such as drying cabinets, dryers, wood-burning stoves, saunas, etc. Then an indoor sensor can be in a neutral place in the house where it is not affected by the foreign heat sources.

Art: 1661 External room sensor, enclosed.



8.5.2 Indoor sensor with fan switch.

An indoor sensor with a fan switch is available as an accessory, intended for wall mounting. Here you regulate the fan speed between LOW - NORMAL - BOOST.

Indoor sensors that regulate indoor temperature (in control method IN) are controlled from this box.

Art: 2407 Fan control with indoor sensor.



8.5.3 Damper Feet 4-pack

De-vibrating rubber-damped feet are included in the delivery of a new heat pump.



8.5.4 Air filter

Filter for exhaust air in the house must be checked/cleaned and replaced regularly. We recommend that you change to a new filter at least once a year.

Art: 1853 Air filter-EX, 1-pack, Z-Pleat G4



9 Commissioning

9.1 Re-filling the system

Fill the system by opening the filling valves (2 and 3). The heat pump is equipped with an automatic vent.

Close the filling valves (2 and 3) when the pressure in the system is between 1.0 - 1.5 bar.

In frost-sensitive installations, the system should be filled with glycol or brine alcohol. Potash must never be used.

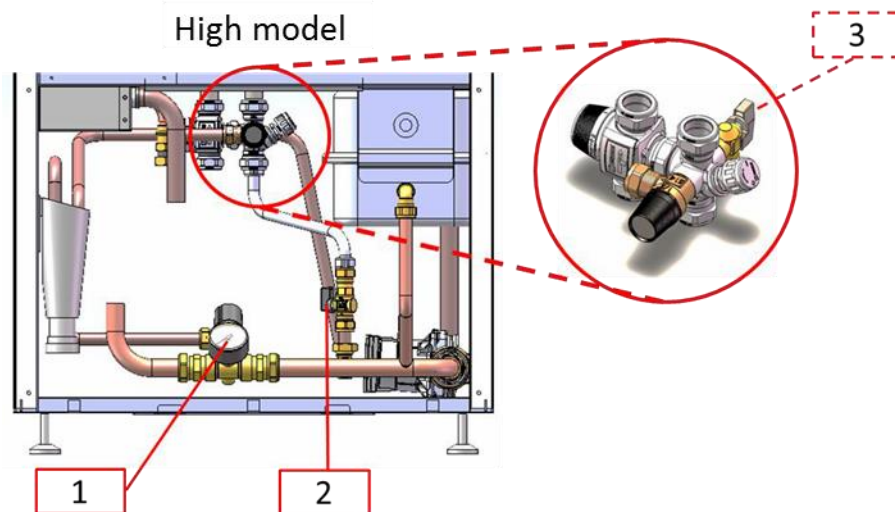

9.2 Venting the system

Bleed the radiators / floor heating coils carefully from air so no air pockets remain. The heat pump is equipped with an automatic vent. Ensure that the automatic breather valve cap is screwed tightly so that the air can come out. See section 22.

Components, item 34.

Check the system pressure and re-fill with water if the pressure has dropped.

If there are large amounts of air in the circulation system, the air can block the circulation pump.

The compressor then stops with the message "Invert alarm (0)". Then turn off the main switch, wait 10s, and turn it on again.

This may need to be repeated several times with a few hours or a few days apart.

Check the pressure again after some day and fill with water if the pressure drops.

9.3 Venting of hot water tank

Drainage of the tap water system takes place automatically as you open a hot water tap in the house.

9.4 Draining / emptying the system

When draining the system, the main switch must always be in the off position.

Emptying of hot water tank.

Close incoming water (1).

Loosen the hose (2) and place its end against the floor drain.

Open drain valve (3) as well as one or more drain valves in the housing and allow the water to flow into the drain.

NOTE!

The main power must never be switched on unless the system is filled with water.

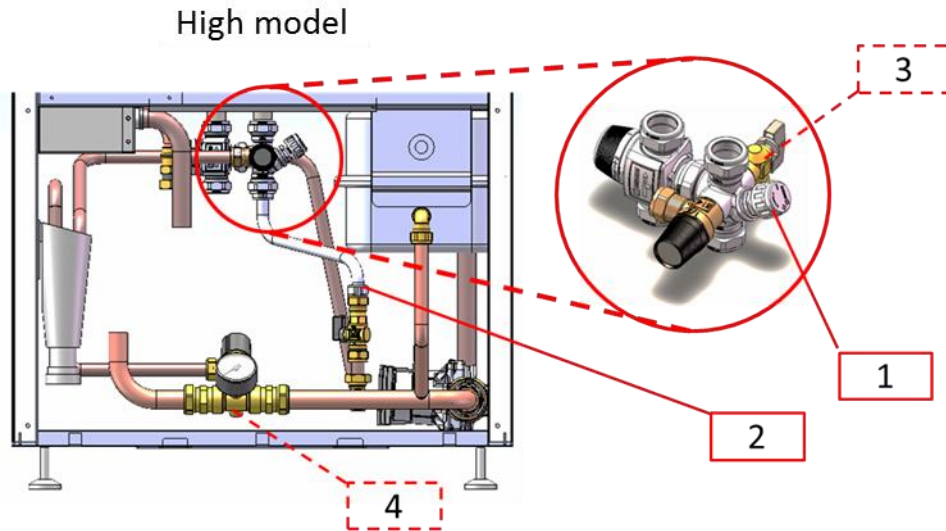

9.5 Emptying the heating circuit.

Open $\frac{1}{4}$ " of the bottom plug (4) that is concealed on the back of the gauge package. Connect a suitable $\frac{1}{4}$ " connector with hose and connect the end of the hose to the floor drain.

Open the appropriate coupling in the housing so that the water flows into the drain.

10 Adjusting the system

In order to get the right heat balance in the house, shunt groups, floor loops and radiators must always be adjusted as below.

This is especially important when "Type of control" "IN" is selected. See section Settings during installation / Selection of regulation below.

When the correct heat balance as a whole is adjusted, you can lower the temperature in some rooms, e.g. bedroom, with its thermostats.

10.1 Adjustment of shunt groups

The balance between the different shunt groups, usually one per each floor, is adjusted through the flow to each shunt group. Adjust the flow from the shunt group using the throttle valves that are normally mounted on each return line, so that even heat is distributed to each shunt group (the housing plan).

Never balance with the aid of overtemperature thermostats.

- (A) Increased flow gives more heat to the targeted shunt group, and at the same time gives less heat to other shunt groups.
- (B) If you want to increase heat to a shunt group where the flow cannot be increased, one must reduce the flow to other shunt groups, which gives the same effect.

10.2 Adjustment of floor loops

Start by opening all thermostats fully. The flow to each loop is adjusted separately, so that even heat is obtained on all loops in the respective shunt group.

- (C) Increased flow gives more heat to each loop.

10.3 Adjustment of radiators

Start by opening all thermostats fully. If necessary, adjust the flow to each radiator. This is normally done by adjusting the maximum flow in the radiator valve and can sometimes require special tools.

11 Settings during installation

Note! This section [11](#) applies to the installer company and settings shall not be carried out by the house owner.

Installation settings must be made in the menu "Advanced settings".

Turn the knob to "Advanced settings" / "General settings", press and hold the button for 5 seconds. Then the installer menu opens and all selections are available.

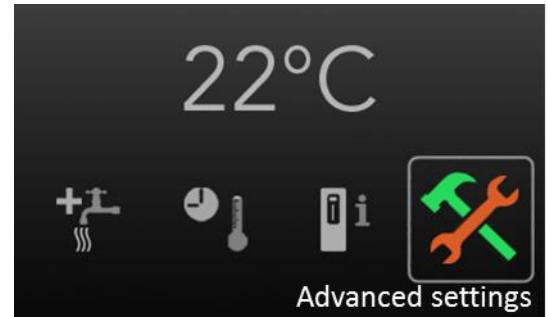

11.1 Basic Settings

Proceed to "/ Basic installation /". This is a shortcut menu where the parameters that are normally set during installation are collected. All of these are also available under their respective submenus together with other less commonly used parameters.

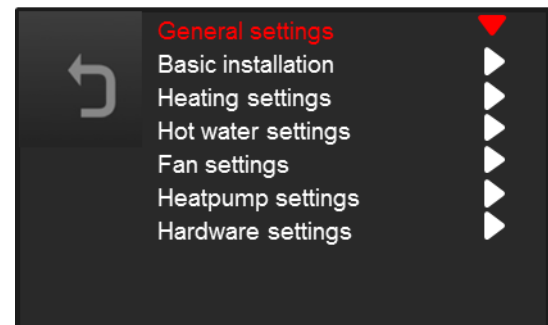

11.1.1 CW Heating mode

Options: Floor or Radiator.

Here you choose which type of heating form is desired

11.1.2 CW Control mode

Options: OUT, OUT and IN or IN.

Here you choose if you want to control the indoor temperature via the output, output & input sensor or input sensor. See 14.2 Choice of regulation.

11.1.3 CW Heating Curve

Options: 1 - 10.

Here you select the appropriate heating curve based on the table, see section 14.1.

Default: Underfloor heat= 3

Radiator= 7

NOTE: When "UV control method IN" is used, the "UV heating curve" function goes out and is not visible in the display.

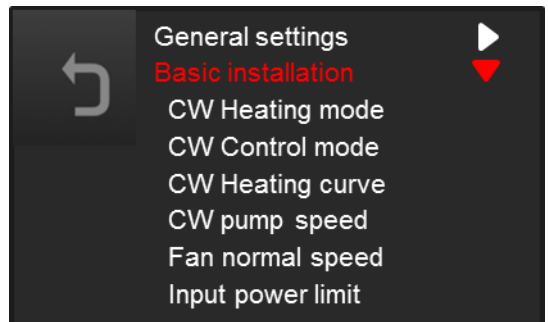

11.1.4 CW Pump Speed

Options: 30 - 100%.

Here you select the appropriate speed for the circulation pump.

See 17. Pump diagram.

11.1.5 Fan normal speed

Options: 0 - 100%.

Here you select the appropriate speed for the fan. See 18. Fan Chart.

11.1.6 Input power limit

Options: 0 - 12000W Electric input power limitation value. May be adjusted to reduce the needed fuse size, otherwise left at 12000 W.

Fuse size	Power limit value
16 A	3300 W
20 A	4200 W
25 A	5200 W
32 A	6600 W
40 A	8300 W
50 A	12000 W

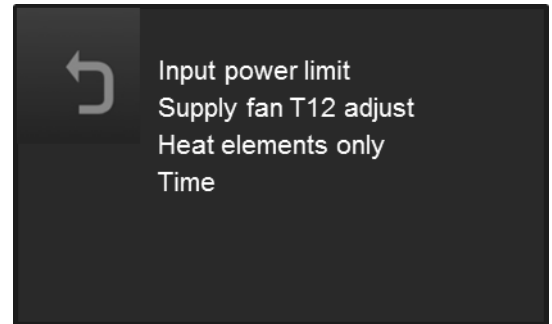

NOTE: In configuration, the maximum input power limit can only be lowered, not increased. Once power limit is reduced, the only way to increase the maximum power limit again is by replacing the entire control unit.

11.1.7 Supply fan T12 adjust

Here you set the air fan speed in relation to the heat pump's fan setting.

Factory setting -30%. This corresponds to about -10% in supply air flow compared to the exhaust air flow.

11.1.8 Heat elements only

Here you choose if you want to run the heat pump with only electricity supply. Factory setting: No.

11.1.9 Time

Time and date are preset but can be adjusted here.

11.2 Choice of regulation

The type of regulation should be selected during the installation to OUT&IN (outdoor & indoor), UT (outdoor) or IN (indoor).

This is done in the menu "Advanced settings" "Heating settings" "UV Control method".

Factory setting is Outdoor & Indoor Control.

11.2.1 Control method OUT & IN, Factory setting.

The supply temperature to the heating system is controlled by the outdoor temperature according to a temperature curve.

The supply temperature is slightly adjusted by the measured indoor temperature compared to the desired value, but there is no guarantee that the CW room setting value will be exactly met.

The heating power, i.e. compressor power plus any additional power, is adapted to the calculated power requirement. Curve 1-10 can be selected, where 1 is used for low-temperature systems with a small heating requirement, and 10 for high-temperature systems with a large heating requirement. The selected curve can be fine-tuned in the user menu, see section "fine tuning indoor temperature".

When changing the temperature curve, the fine adjustments that are made remain.

11.2.2 Control method OUT

The supply temperature is controlled the same as above but there is no adjustment for indoor temperature.

11.2.3 Control method IN

The supply temperature is controlled by the house's average indoor temperature. The method is best suited when only radiator heat is used.

There is a risk of temperature fluctuations due to slowness in heating systems if underfloor heating is used.

The indoor temperature sensor is located in the heat pump's exhaust air intake but alternatively may an external indoor sensor be used.

The thermostats in all larger rooms should always be left completely open, i.e. in max position or completely removed.

Bedrooms can be regulated with thermostats.

11.2.4 Temperature Curve

Heating system	Floor heating max. 35° C	Floor / radiator 35/55° C	Radiator 55° C	Radiator 65° C
Curve selection	3-5	6-8	6-8	8-10

	1	2	3	4	5	6	7	8	9	10
20	16,9	17,0	17,0	17,0	17,3	17,5	17,4	17,5	17,8	17,9
15	19,1	19,7	20,3	20,8	21,5	22,2	22,7	23,4	24,1	24,8
10	21,3	22,4	23,6	24,6	25,8	27,0	28,1	29,3	30,5	31,7
5	23,5	25,2	27,0	28,4	30,0	31,7	33,4	35,2	36,8	38,5
0	25,5	27,6	30,0	31,8	34,0	36,1	38,4	40,6	42,7	44,9
-5	27,3	30,0	32,6	35,0	37,6	40,2	43,1	45,7	48,2	50,9
-10	29,1	32,1	35,2	38,1	41,0	44,1	47,5	50,4	53,5	56,7
-15	30,8	34,1	37,7	41,1	44,4	47,9	51,7	55,0	58,5	62,2
-20	32,4	36,2	40,2	44,1	47,7	51,7	56,0	59,5	63,5	67,7
-25	34,1	38,2	42,7	47,2	51,1	55,4	60,2	64,1	68,5	73,2
-30	35,8	40,2	45,2	50,2	54,4	59,2	64,4	68,6	73,5	78,7
-35	37,5	42,2	47,6	53,2	57,7	62,9	68,6	73,2	78,5	84,2

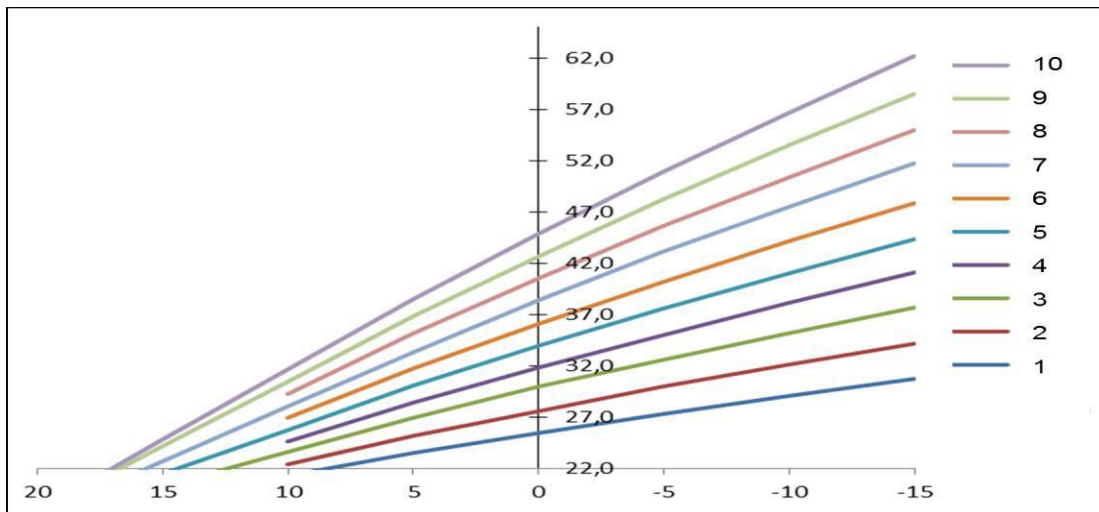

11.3 Blocking of interfering resonances.

The RX35/50/65 has a frequency controlled compressor. At certain frequencies, resonance sounds can sometimes occur in the house. To minimize disturbing resonance sounds, the control has a blocking function which allows the control card to jump over three (5) mutually independent frequencies.

The function causes the control card to skip a certain frequency (Hz) +/- 2.0Hz (RX50 and RX65) or electricity. +/- 1.5Hz (RX35). If one perceives that one has a disturbing frequency at 63Hz, then the control card's blocking parameter is programmed to 63.0Hz, which means that the frequencies 61.0 - 65.0Hz (or 61.5-64.5 Hz for RX35) are blocked.

Then the compressor slowly accelerates up to the lower frequency and passes quickly past to the upper. The disturbing sound is minimized. A larger area can be blocked by entering two or three frequencies.

E.g. for RX50 61.0 - **63.0** - 65.0 - **67.0** - 69.0.
Which for 63.0 Hz and 67.0 Hz gives a blocking from 61.0 to 69.0 Hz.

Go to "Advanced settings" / "General settings" hold the button for 5 seconds.

Go to "Heat pump settings" / VP compressor "/" Blocked frequency 1 ". Specify the frequency to be blocked.

Proceed to "Blocked Frequency 2, 3,... etc. if desired.

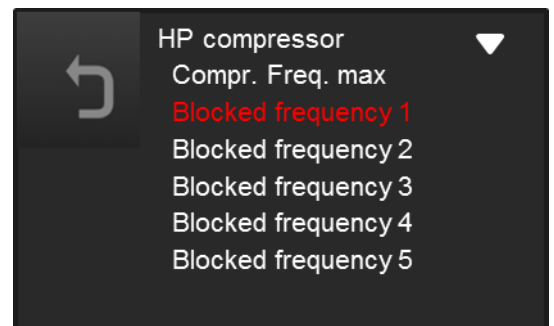
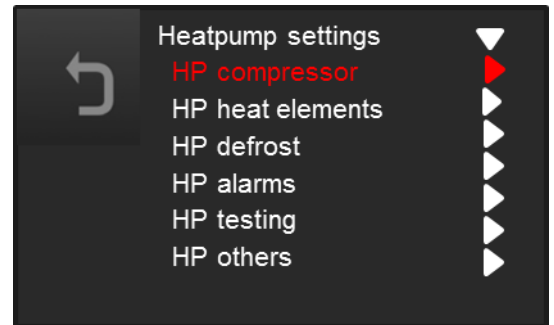
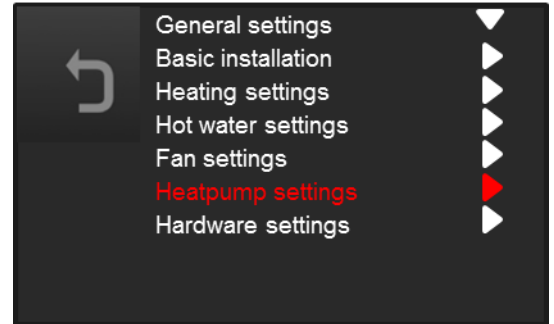

11.4 Maximum frequency of the compressor

At lower airflow, the compressor's maximum power should be reduced for the lowest noise level and smoother operation.

Air Flow l/s	Frequency RX35	Frequency RX50	Frequency RX65
>65	-	-	No reduction
50-65	-	No reduction	82
35-50	No reduction	68	68
27-35	No reduction	55	55
21-27	40	-	-

To change parameter <Comp. Freq. max.> options can be found in the menu: "Advanced settings / Heat pump settings / VP compressor/".

11.5 Legionella elimination

To eliminate any occurrence of legionella bacteria, the tank's water temperature is raised to 65° once a week. Legionella bacteria die when the temperature exceeds 50-60° C.

This takes place automatically with a warm-up start at 2 am every Monday morning.

The function can be switched off if desired.
Go to "Advanced settings" / "General settings" hold the button for 5 seconds.
Proceed to "Hot water settings" / "Per extra VV temp"
YES = function ON, NO = function off.



11.6 Operation with heat elements only

There is the possibility to set the function "Heat elements only" in case of e.g. malfunctions in the compressor module.

The compressor is then not run at all and all heat is produced by the additional elements.

If you have selected "Heat elements only", the attached picture is shown under "Operating information"

Go to "Advanced settings" / "General settings" hold the button for 5 seconds.
Proceed to "Basic settings" / "Heat elements only". Change NO to YES.

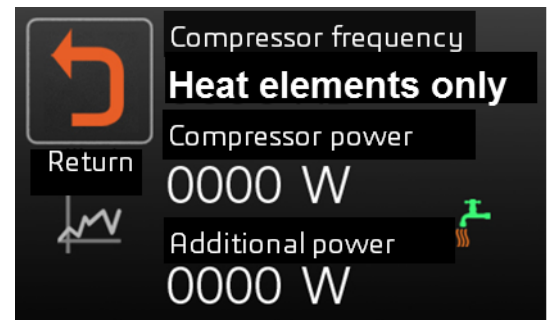

11.7 Operation with fan off

When the house is under construction or major renovation work is in progress, you can run the heat pump as an electric boiler without the fan running. In this way, dust and dirt avoid being sucked into the heat pump, which can damage vital parts of the compressor module and get stuck in the filter.

Turn off the fan by:

Go to "Advanced settings" / "General settings" hold the button for 5 seconds.
Proceed to "Fan settings" / "Fan off". Change NO to YES.

The control will automatically switch over to "Heat elements only" operation.

11.8 Start-up and installation control

At start-up, installation inspection must be done according to the protocol at the back of this manual.

The protocol must be completed in full.

11.9 Adjustable HW overheating limit

The function allows you to connect an external heat source that can emit high water

temperatures (above 73° C) e.g. solar collector system, water jacketed stove or the like.

VV overheating limit is an adjustable value.

Go to "Advanced settings" / "General settings" hold the button for 5 seconds.

Proceed to "Hot water settings" / "VV Overheat limit" the value is adjustable 0-110° C, default value 73° C.

The parameter shall be set to a value of 3-5° C higher than the highest temperature that can be achieved in the water tank.

If the tank temperature exceeds the set value, the alarm "Hot water overheat" is activated.

11.10 Double Heat Curves

There are two different heating zones that can be controlled via the heat pump. A function that is useful when heating the house with both radiators and underfloor heating.

A separate shunt group with 0-10V control signal and a separate circulation pump is required. The function requires that the CW control mode "OUT & IN" or "OUT" is selected. The function is not possible in CW control mode "IN".

When the heat pump is delivered, this function is set to Off.

Function Description:

If heating zone 1 and 2 have different supply temperatures, zone 1 should have the higher temperature (radiators) and zone 2 should have the lower temperature (floor heating). The values of the two heat curves are individually adjustable.

The heating curve for zone 2 cannot be set higher than the heating curve for zone 1. Control method can be selected individually for OUT or OUT & IN.

Fine-tuning the temperature is common to zone 1 and zone 2.

If UV control method is selected for OUT & IN, the indoor temperature in zone 1 must be measured with an external indoor sensor TE3 (Terminal X4: 3-4), and the jumper mounted on the control board terminal J1 must be moved from outlet 1-2 (INT) to 2 -3 (EXT) according to Figure 2.

If UV control method 2 is selected for OUT & IN, the indoor temperature in zone 2 is measured with an external indoor sensor TE9 (Terminal X5: 9-10) as shown in Figure 3.

UV control method 2 controls the external shunt valve's flow temperature which is measured with sensor TE8 (terminal block X5: 7-8) as shown in Figure 3.

The control signal to the external shunt group is connected to terminal block X3: 13 (0-10 volts) and X3: 14 (GND = ground) according to Fig. 4.

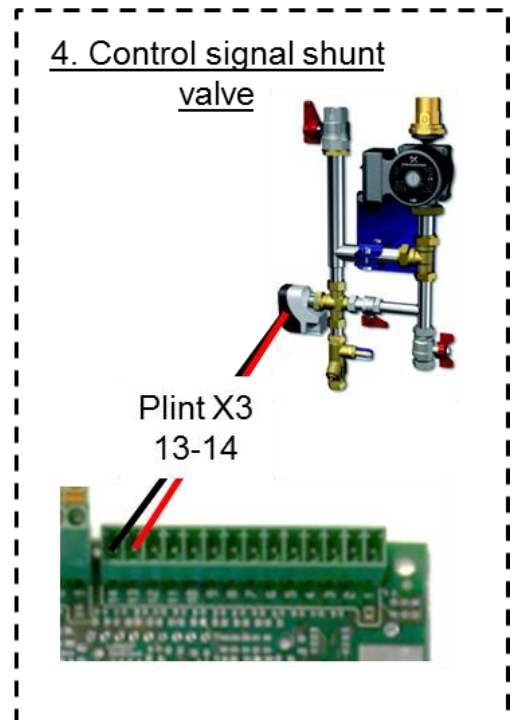
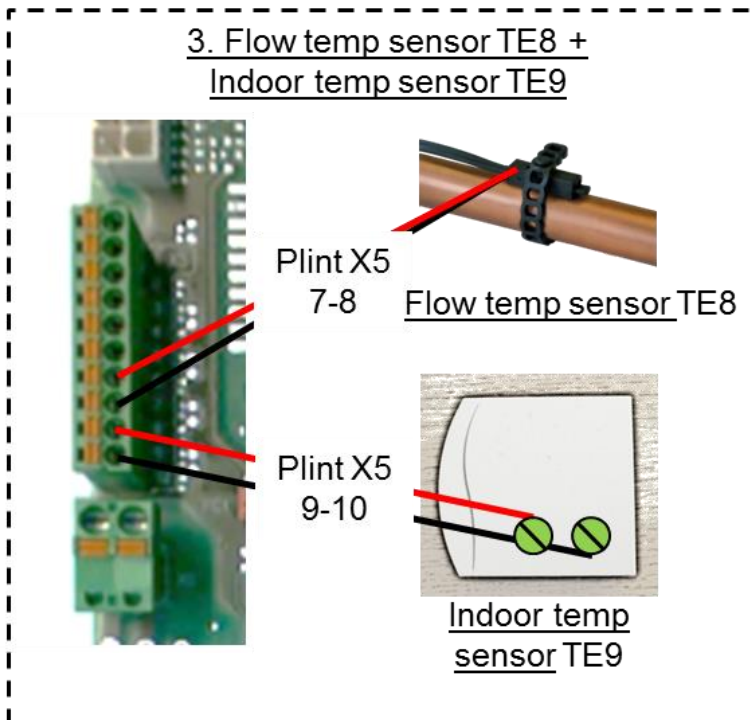
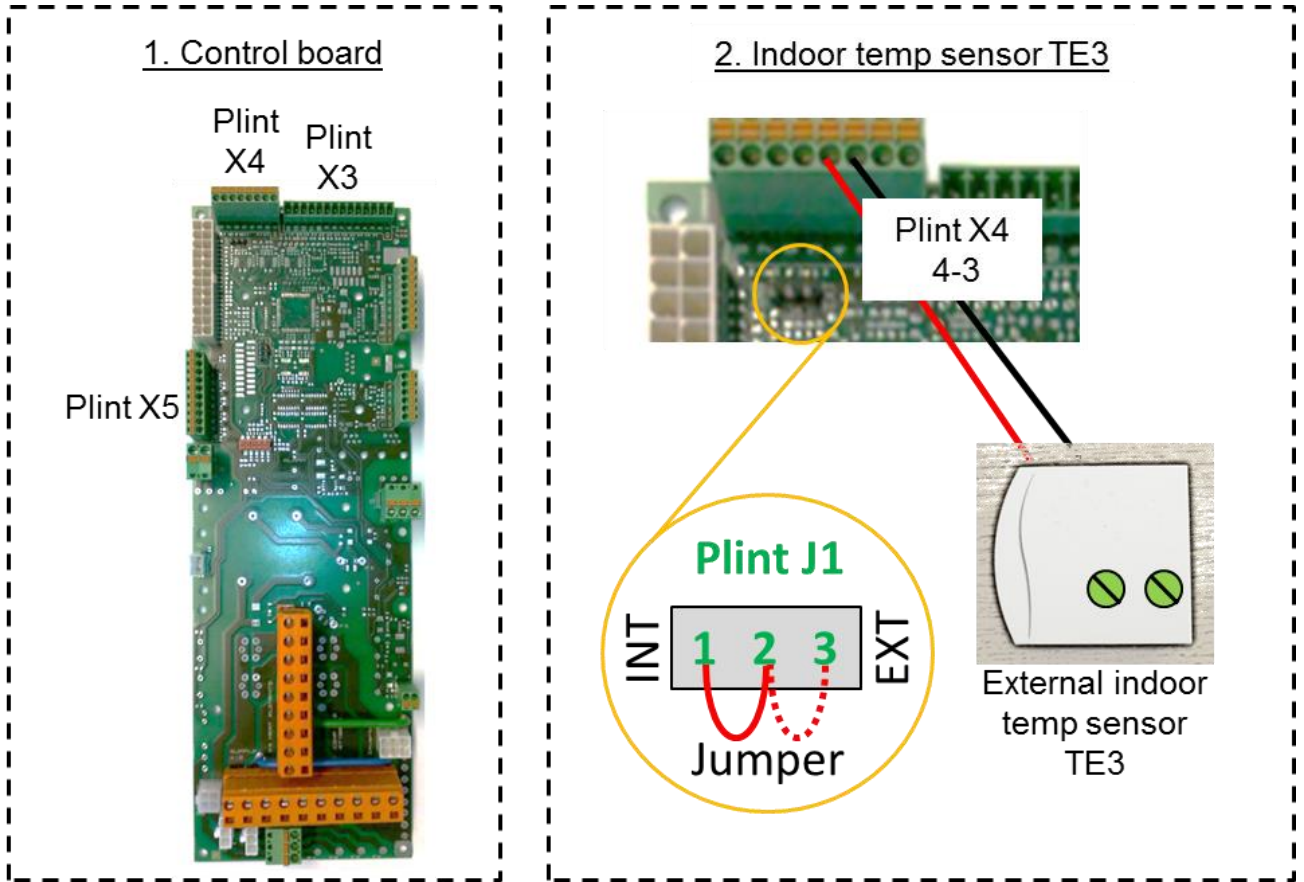

Adjusting double heat curves

Go to "Advanced settings" / "Heating settings" / "UV Double heating curves":
Change OFF to ON.

Setting appropriate values is done by proceeding to:

	CW Heating mode 1		CW Heating mode 2
	CW Control mode 1		CW Control mode 2
Zone 1	CW Heating curve 1	Zone 2	CW Heating curve 2
	CW Room setting 1		CW Room setting 2
	CW Room factor 1		CW Room factor 2

The UV room factor value is normally set at 2.0° C for underfloor heating and 3.0° C for radiator heating. The room factor determines how much the indoor temperature affects the flow temperature and is usually left at default value.

11.11 External mixing valve control.

An external mixing valve (shunt valve) can be controlled when external water tank with external heat source is used, it can be solar collector system, water-jacketed stove or the like. This function is described in a separate document that is provided via ComfortZone's website.

Go to "Advanced settings" / "General settings" press the button for 5 seconds. Proceed to "Heat pump settings" / "HP Other" / "External - mixing valve in use".

"External mixing valve" is set to Off position when. Delivered, If you want to connect the external mixing valve, set the function to On.

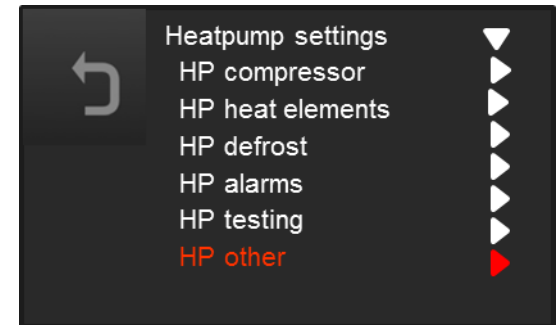
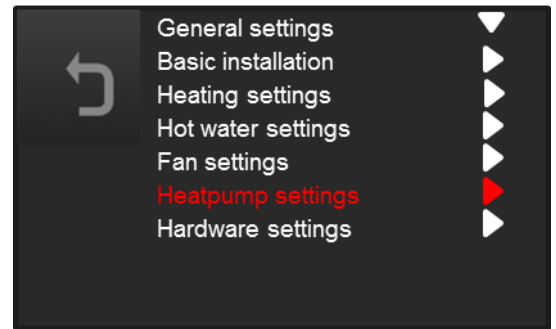

11.12 Synchronization with solar panels.

There is a possibility to synchronize solar panels with the function "Solar panel". This function is described in a separate document that is provided via ComfortZone's website.

Go to "Advanced settings" / "General settings" press the button for 5 seconds. Proceed to "Heatpump settings" / "HP Other" / "Solar panel sync."

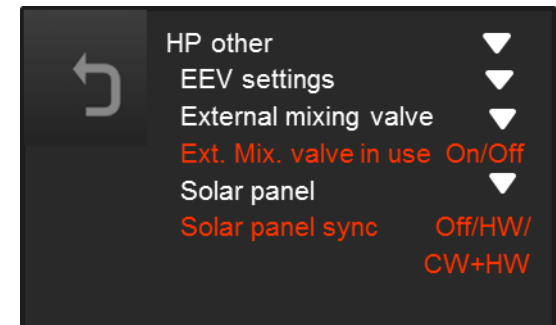

"Solar panel sync" is in the Off position when delivered. If you want to connect the solar panel synchronization set the function to HW or CW+HW.

12 Troubleshooting

12.1 No heat to the elements (circulation water) although the compressor is running

- Cause:
- All heat goes to the hot water tank first. If there is a heating requirement, the heat is switched to the circulating water after 30 minutes. (Time adjustable).
 - (D) Gear valve or gear valve control failure. If this is the case, you will receive an alarm "Overpressure hot gas" or "Over temp VV" after 1-2 hours.
- Measure:
- Wait until the heat is switched over to the circulation water.
 - (E) You can also turn down the desired hot water temperature to e.g. 0° C. The heat should then be switched over to the circulation water within one minute.

12.2 The heat pump heats up the HW tank and then stops

- Cause:
- The heat pump heats up the hot water tank and then stops.
- Measure:
- No action needed. When the temperature drops, the compressor will start again.
 - (F) If you want to test the heat for the radiator alt underfloor heating, the system can temporarily raise the desired room temperature, for example to 30° C, and / or temporarily switch to a higher heating curve. Remember to lower to normal value when the test is complete.

12.3 Overheated auxiliary heater - smell of burnt rubber

- Cause:
- Air in the auxiliary heater. The heat pump is commissioned without water filling first. If the heater has been in the switched-on position for an extended period of time, unpleasant odors may occur. There is no risk of fire.
- Measure:
- Add water and vent the system.
 - (G) Reset the overheat protection by pressing the reset button.
 - (H) If there is an unpleasant smell, the insulation on the heater must be checked and, if necessary, replaced with a new 9 mm Armaflex mat.

12.4 Poor hot water capacity.

- Cause:
- Too low values set for hot water temperature and hot water priority.
- Measure:
- Check the settings. Higher values give higher hot water capacity.

12.5 The heat pump completely shuts down and does not start

- Cause: May be due to power failure or a fuse being broken.
- Measure: - Check that there is 230 V voltage up to the main switch and that the zero is connected.
- (I) Check that the fuses F5 and F6 on the control board are full. See section 20 Connection terminals and fuses.

12.6 Overheating protection cannot be restored.

If the "Heater overheat alarm" cannot be reset with the red reset button described in section 16.6, even if the heater is not overheated.

- Cause: May be due to:
- (J) A gap in the overheat protection.
- (K) Cable break between overheat protection and control board.
- (L) Interruption of the control card.
- Measure: Contact your service partner.

13 Alarms

13.1 Filter Change Alarm

Cause: - The air filter must be changed or cleaned

Measure: - Turn off the main switch.

(M) Replace or vacuum the filter. The filter should always be changed at least once a year.

(N) Reset the alarm on the display unit.

13.2 High Gas Pressure Alarm

Cause: The pressure has been too high after the compressor and the high-pressure switch has tripped.
In new installations, the fault usually depends on air in the system, lack of water circulation or too small radiator system.

The alarm may also be due to a loose contact in the HP alarm circuit.

Measure: - See measure at Inverter Alarm 16.5.

13.3 Low pressure alarm 1

Cause: The evaporation temperature measured with the sensor (TE6) is too low. This should be above -23°C . Usually depends on too low airflow. Rarely can the expansion valve's smallest opening be too small.

Measure: - Check if the filter is dirty or clogged.
(O) If the filter is older than 1 year, replace the filter.
(P) If the house is newly built or rebuilt, the filter may be clogged by building dust, change filter after the new or remodel is completed.
(Q) Verify air flow measurement.
(R) If no error was found, analyze the log file for error Cause.

13.4 Low pressure alarm 2

Cause: The evaporation pressure measured by the low-pressure switch (IN4) is too low for at least 3 minutes. This should be over 1.5 Bar.

(S) Stop in the air flow

(T) Dirty filter.

(U) All refrigerant has leaked.

- (V) Expansion valve / motor / control error.
- (W) The alarm may also be due to interruptions in the LP2 alarm circuit.
- (X) Rarely, the expansion valve's smallest opening can be too small.

- Measure:
- Stop the alarm. If it cannot be stopped, it is because all refrigerant has leaked or because it is a loose contact in the alarm circuit.
- If the alarm cannot be stopped:
- Check the alarm circuit by shorting the flat pins on the low-pressure switch. If the alarm can then be stopped, the alarm circuit is complete and all refrigerant has probably leaked, otherwise it will interrupt the alarm circuit.
- If the alarm can be stopped:
- Check that the fan is working.
 - Check that the filter is not clogged and replace if necessary.
 - Check that air adjustment is made.
 - Check that the air ducts are not clogged.
 - Increase the fan speed.
- If the alarm still comes back after a few minutes of operation:
- Check the expansion valve's function by studying overheating and valve opening in the menu **Advanced settings / Measurements / Expansion valve/**
- The valve position is automatically controlled by a feedback control so that the value *Temperature diff* is about the same as the value *Estimated setting* but *valve position* varies. If the valve works properly then decrease *Temperature diff* to increase *Valve position*.
- After five minutes of operation, the value of *Temperature diff* should be maximum +/- 10 K from *Estimated setting*.
- If no error was found, analyze the log file for error Cause.

13.5 Inverter alarm (0)

- Cause: The inverter has detected an error.
- Measure:
- Turn off the main power switch and leave it off for 10 seconds. When the power is turned on again, no errors should be indicated on the display.
- (Y) Reset the alarm
- (Z) If the alarm reactivates, contact your service provider.

13.6 Heater overheat alarm

- Cause: This means that the protection alarm for the element of the additional heat source has been activated. This is usually due to poor circulation. May also be because connector X9 (auxiliary heater) is not connected or due to a fault in the control card.
- Measure:
- Check the pressure on the manometer.

- (AA) Air the system. Bleed the radiators/floor heating from air.
- (BB) Check that there is circulation in the system.
- (CC) Reset the alarm by pressing firmly on the red pushbutton to the overheat protection located next to the type plate, left side about 45 cm from the floor.
On heat pumps with software version 1.5 and earlier, the alarm is reset by pressing both the red push button and resetting the alarm on the display.
- (DD) Reset the alarm
- (EE) If the alarm is reactivated, contact your service provider.

13.7 Hot water overheat alarm

- Cause: The gear valve is stuck in the VV position.
- (FF) Fault in the shift valve, connection cable or the gear valve relay in the control.
- Measure: - Check if the gear valve can be controlled or not by going to *Advanced settings / Heat pump settings / VP test /*.
Set *VP test* to, *Yes*
Set *Hot water* to alternate mode *Yes* and *No* and check that the gear valve switches position. The red indicator washer should be rotated about 1/6 turn at each shift. If the gear valve cannot be controlled in this way:
- (GG) Break the main switch.
 - (HH) Check that the gear valve is properly fitted and secured with the locking bracket.
 - (II) Check that the fuse for the gear valve (F1 in the control unit) is full.
 - (JJ) Check that the cable connection is properly mounted in the gear valve.
 - (KK) Check that the connection cable is properly mounted in the control unit.
- If no fault is found, pull out the connector M3 from the control card, turn on the main switch again and measure the voltage directly on the contact pins between pin 1 and pin 3, ie the two upper pins.
- | | |
|--------------------------|----------|
| In hot water mode - Yes | 230 V~ |
| In circulation mode - No | max 50V~ |
- If the voltage on the M3 connector switches as above, the control board will work correctly and the fault will be in the gear valve motor or in the gear valve cable.
If the voltage does not change, the control card is faulty and this must be replaced.

13.8 Sensor fault TE0-TE2

- Cause: This is because the sensor's measured resistance value is outside the specified range 0.5 - 1.5 kΩ.
Depends on a gap in the contact, interruption or short circuit in the sensor or transducer circuit.
Note that sensor faults are often intermittent, i.e. the sensor is functioning correctly in the case of control measurement, even though there is a loose contact inside it and the problems

return later.

- Measure:
- Check that the cables are properly connected.
 - (LL) Check that the connector is firmly attached to the control board.
 - (MM) Check the sensor resistance.
 - (NN) If no fault can be found, change the sensor anyway.

13.9 Defrost alarm

- Cause:
- The defrost does not end within the given time limit (60 min). Usually depends on incorrect sensor (TE7).

- Measure:
- Replace TE7 sensor.

13.10 Unknown HP box alarm

- Cause:
- The controller cannot identify the VP box. Probably due to a broken electrical contact or connection failure.

- Measure:
- Check all signal cables and connectors.

13.11 Heating overheat alarm

- Cause:
- The alarm limit set for maximum supply temperature (TE1) is exceeded. (= Max supply temperature +5 K.) Probably due to lack of circulation. Can also be because the elements in the radiator circuit are out of order, are too small or that push pumps are not operating.
- Factory setting for alarm limit is:*
 For underfloor heating 45 ° C (Max supply 40°
 For radiator heating 75 ° C (Max supply 70 °

- Measure:
- Check that the valves for the circulation circuit are open.
 - For indoor temperature control, check that at least half of the room thermostats are fully open (max. Position).
 - Make sure that heat comes out to the elements / floor heating distributor.
 - Check that any over-temperature protection in the floor heating distributor does not stop the circulation.
 - Check that the circulation pump (and any push pumps) are running. The circulation pump has a built-in overheat protection which is reset by breaking the current.

13.12 Heating limitation alarm

- Cause:
- The alarm activates when the temperature limitation of the supply temperature has completely switched off the compressor. Due to poor circulation and / or high return temperature.

- Measure:
- See section 16.12 Heating overheat.

13.13 Heating return max alarm

- Cause: - Excessive temperature of the return sensor.
- Measure: - Check that all push pumps are running.
- Check that the return sensor works correctly
- Shall be connected to X5: 3-4.

13.14 SD memory card error

- Cause: - Comes from faulty or missing SD memory card.

- Measure:
- Make sure the SD memory card is in place,
 - Check that parameter for this function in the menu Advanced settings/"General settings" hold the button for 5 seconds.
Proceed to "Hardware settings" / "Display settings" / "SD memory card" / "Log to SD card"
 - This parameter should be set to *Yes* if the memory card is in place and *No* if not.
 - The memory card is 4 GB as standard but can be replaced with 8.0 GB, 16.0 GB or 32.0 GB.
 - Make sure the memory card works by connecting it to a regular computer.

13.15 Inverter connection failure

- Cause: - Incorrect parameter.

- Measure: - Check that parameter for this function in the Advanced Settings / "General Settings" menu hold the button for 5 seconds.
Proceed to Hardware Settings / Display Settings / Inverter / Read Alarm Code /
- This parameter should be set to *No*.

13.16 Pressure ratio alarm

- Cause: - Too high a pressure ratio, high pressure is too high in relation to low pressure.
May be due to excessive flow temperature.

- Measure: Check the supply temperature.
See also Measure in section 16.2 High gas pressure alarm, 16.3 Low pressure 1 alarm and 16.5 Inverter alarm (0).

13.17 Hot gas temperature alarm

- Cause: - Too high hot gas temperature, above 120 ° C.
Usually depends on cold media deficiency or that the expansion valve does not open properly.

- Measure: - See section 16.20 EEV Max pos timeout.

13.18 Alarm - Multiple alarms simultaneously

- Cause: - The connectors on the control board probably have been pulled out when the front plate or the cables have come loose

from the terminals.

- Measure:
- Open the large front panel.
Break the main current.
 - Check that all connectors are securely attached to the control board.
 - Check that the cables are properly connected at both ends

13.19 EEV min pos time out alarm

- Measure:
- Check if the filter is dirty or clogged.
 - If the filter is older than 1 year, replace the filter.
 - If the house is newly built or rebuilt, the filter may be clogged by building dust, change filter after the construction work is completed.
 - Reset the alarm.
 - If the alarm reactivates contact your service provider.

13.20 EEV Max pos timeout alarm

Cause: The electronic expansion valve (EEV) has turned the control signal to maximum position for more than 30 minutes.
Cold media deficiency alternatively stops the expansion valve from opening properly.

- Measure:
- Reset the alarm
 - If the alarm reactivates contact your service provider.

13.21 Clock not set alarm

Abnormal clock function. Check the set time and battery. The heat pump can work with a bad battery, but the clock setting is cleared during power failure. If the clock setting is cleared during a power failure, the battery must be replaced.

Note! Do not use the heat pump if the battery is not installed.
Battery type CR1220.

Substantial operation information is stored to EEPROM every four hours, preventing loss of operating information in the event of a bad battery or power failure.

13.22 Condenser temperature alarm

TE5 Heat exchanger out, exceeds 73 ° C (parameter "Condenser temp" limit "in the parameter list). Troubleshooting:
Check the water circulation.

13.23 Room under heat alarm

Room temperature TE3 <2 ° C, for 20 minutes.

13.24 Room overheat alarm

The room temperature TE3 > 100 ° C, for 60 minutes.
Troubleshooting:
Check the sensor.

13.25 Defrost error alarm

Defrosting has not been completed (TE7 > about 10 ° C) within 60 minutes.

Troubleshooting:

The error is usually due to the room temperature being too low, below about 15° C. Then the defrost fails.

Sensor error is another possible explanation. Check TE7.

13.26 Heating minimum alarm

The flow temperature TE1 is below 3.0° C for 20 minutes. The alarm can only be triggered during heating operation.

13.27 Heating freez.danger alarm

The return temperature TE2 is less than 1.5 ° C for 30 seconds. The temperature is also monitored during hot water operation.

13.28 Invalid controller type/version

The text is displayed against the red background at the top of the display. The alarm buzzer beeps continuously and cannot be turned off in this mode. The message indicates that the software in the control card is not compatible with the software in the display unit.

If the alarm occurs during operation, the display or control card is faulty

13.29 PL1 input alarm

Alt 1. Terminal X3: 11 is accidentally connected,

Alt 2. Sensor input error X3: 11.

13.30 Sensor mismatch error TE1-TE2, TE2-TE5, TE1-TE5.

The combination of the two sensor readings is unreasonable.

- There is a sensor error or a poor sensor connection.

- The auxiliary heater may not be working.

13.31 No compressor function error

The alarm is activated when there is no compressor output power when the compressor should be running. The compressor is stopped and all heat is produced using the auxiliary heater.

- The compressor phases may have been switched and the compressor is running in reverse direction.

- The On/off and 0-10V control signals have been switched on the inverter.

- A control signal to the inverter has poor connection.

- There is a problem in the refrigerant circuit.

14 Pump Diagram

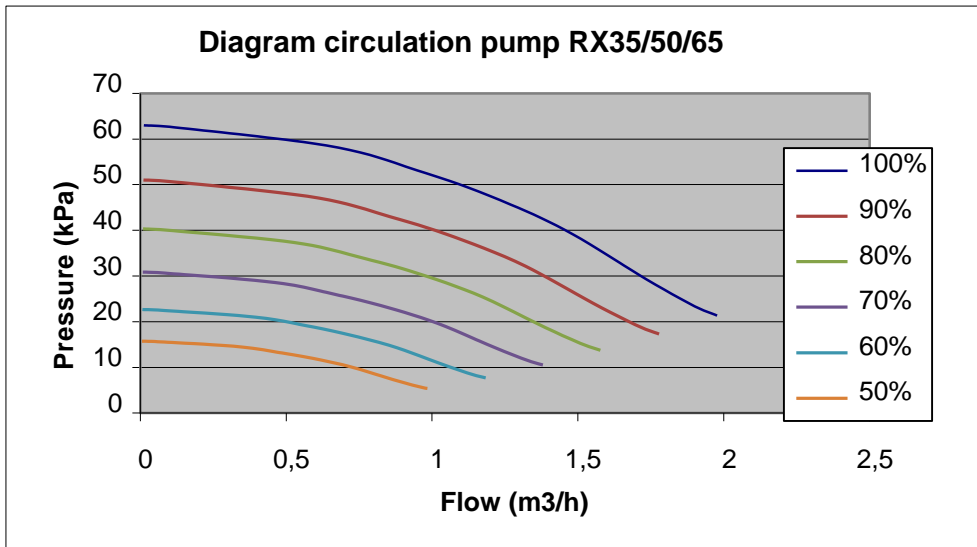

15 Fan Chart

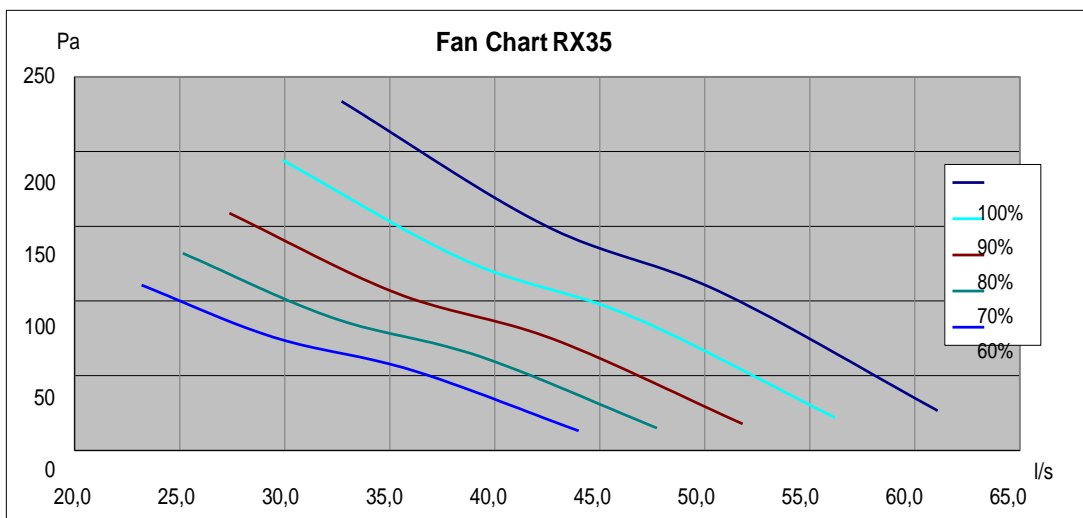
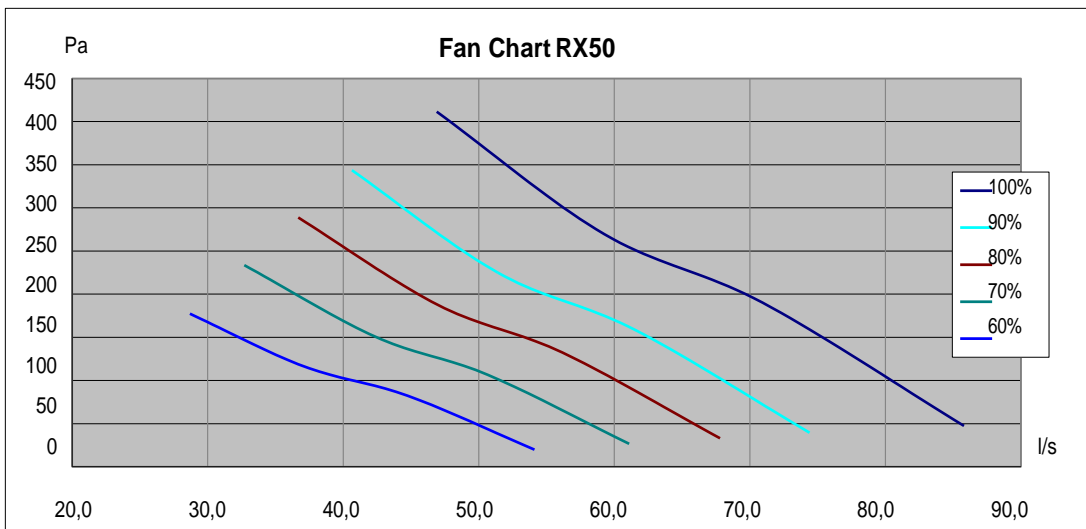
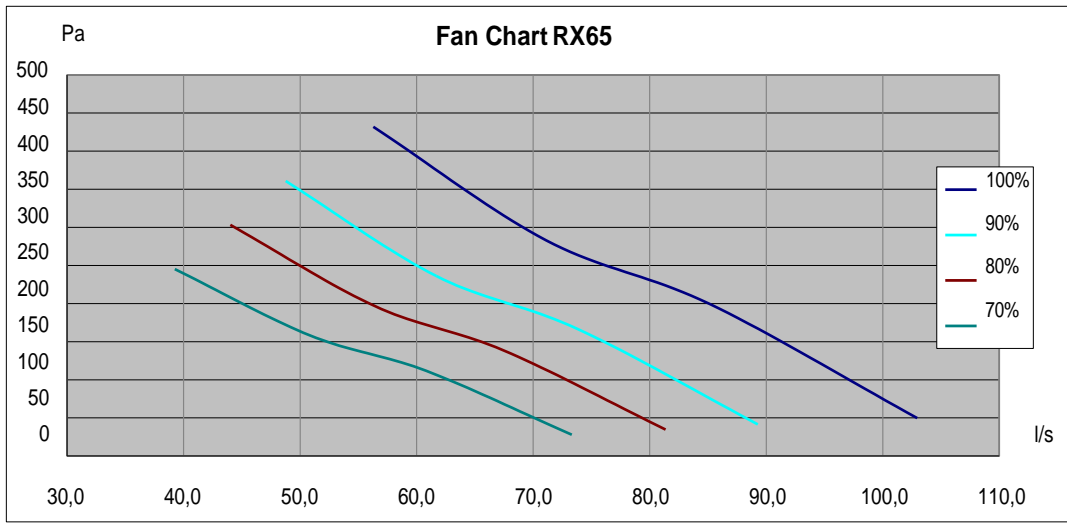

16 System overview RX35 / RX50 / RX65

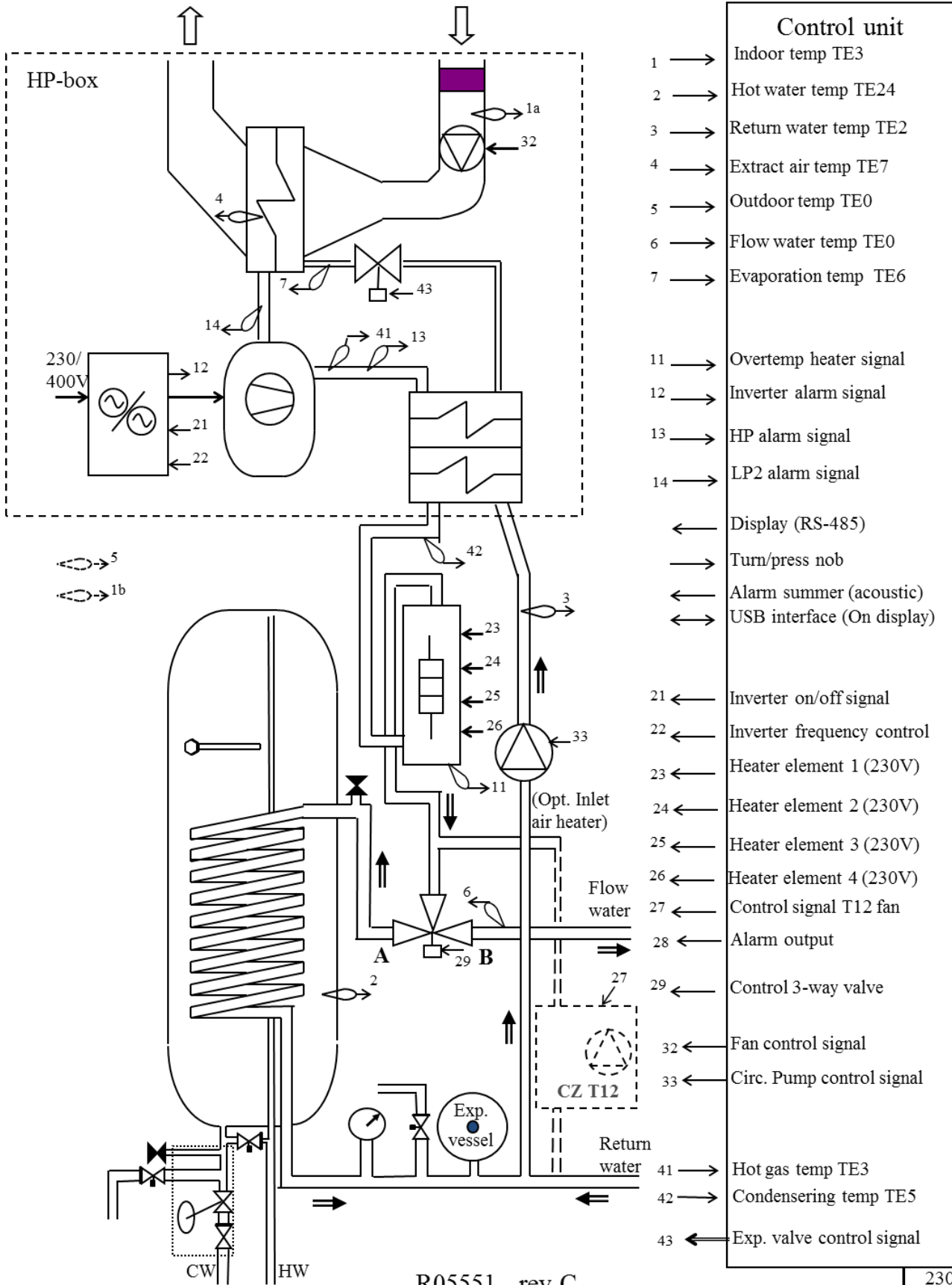

R05551 rev C

230V

17 Wiring RX35/RX50/RX65

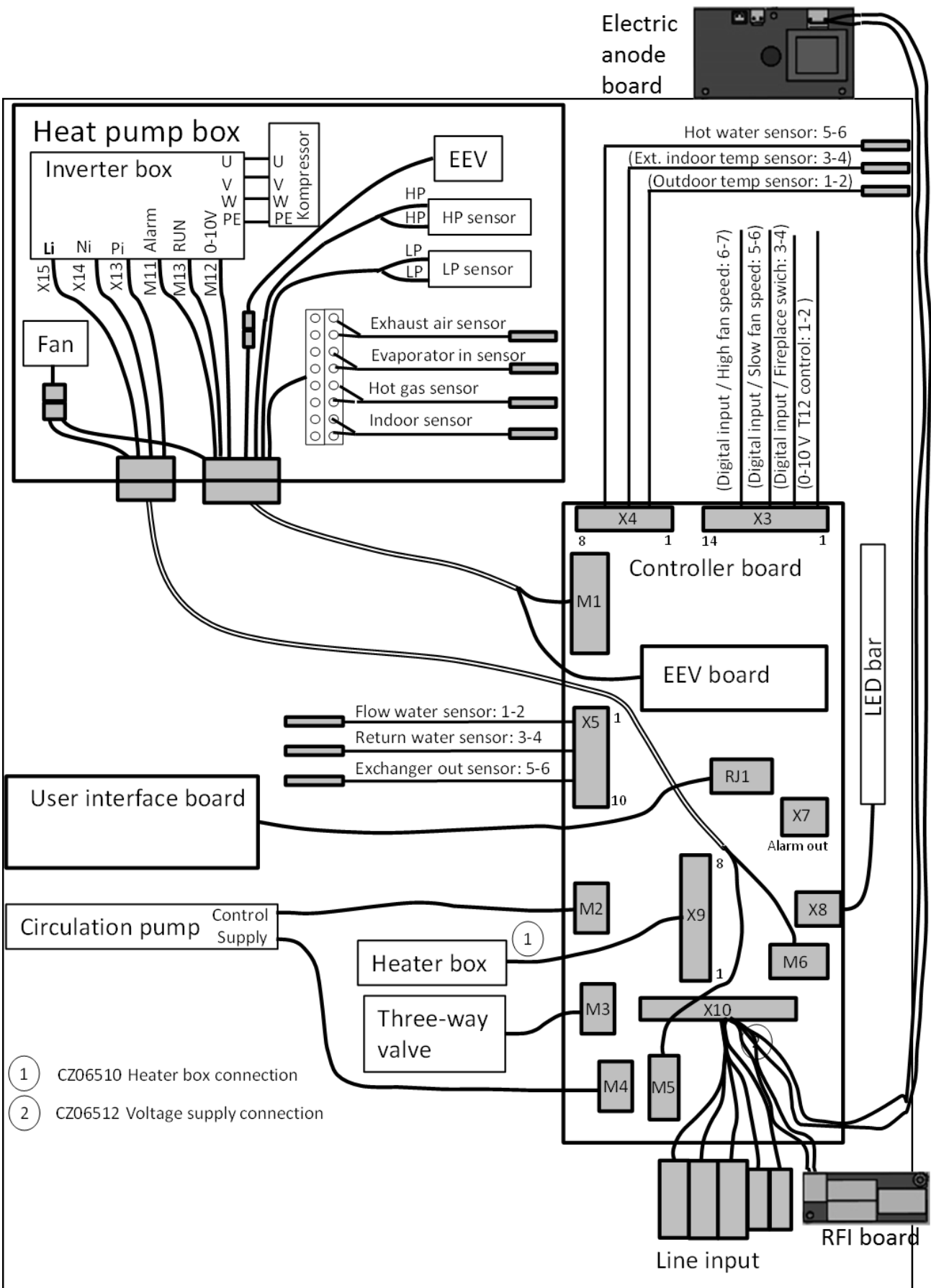

18 Connection terminals and fuses

- F1 = 3-way valve (4.0AT, 5x20 mm)
- F2 = Circulation pump (4.0T, 5x20 mm)
- F3 = Fan (4.0T, 5x20 mm)
- F4 = T12 supply (4.0AT, 5x20 mm)
- F5 = Transformer primary (160mAT, 5x20 mm)
- F6 = Transformer secondary (1.25AmpTT superslow, 5x20 mm)

- M1 = HP box control signals
- M2 = Circulation pump control
- M3 = 3-way valve 230V
- M4 = Circulation pump supply 230V
- M5 = Fan supply 230V
- M6 = Inverter supply 230 V

- RJ1 = Display
- RJ2 = Not used
- X1 = Not used
- X2 = Not used

- X3 = External fan control
- X4 = External sensors
- X5 = Temp. sensors in heat pump
- X6 = Relay
- X7 = Alarm relay
- X8 = LED light
- X9 = Supplementary heater
- X10 = Incoming power connection
- X11= T12 supply

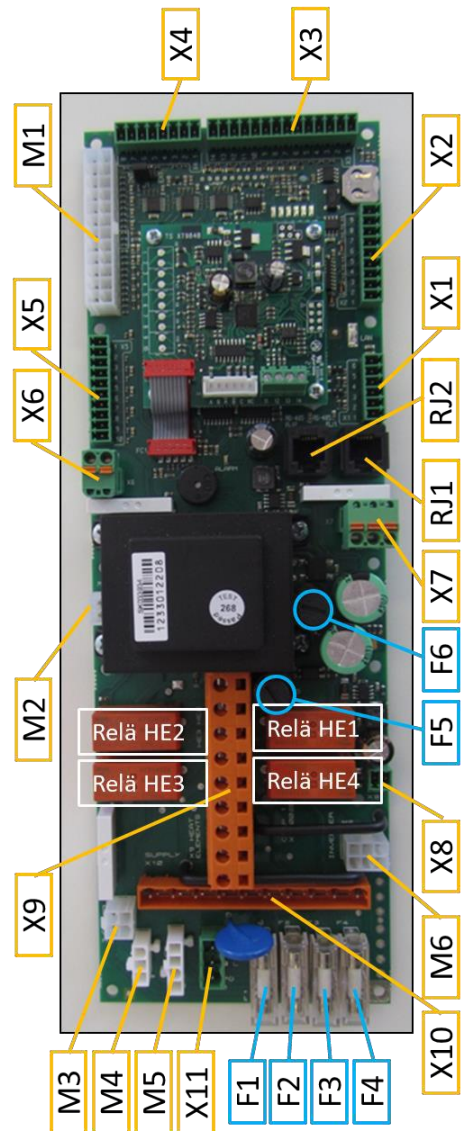

18.1 Connection to auxiliary heater X9

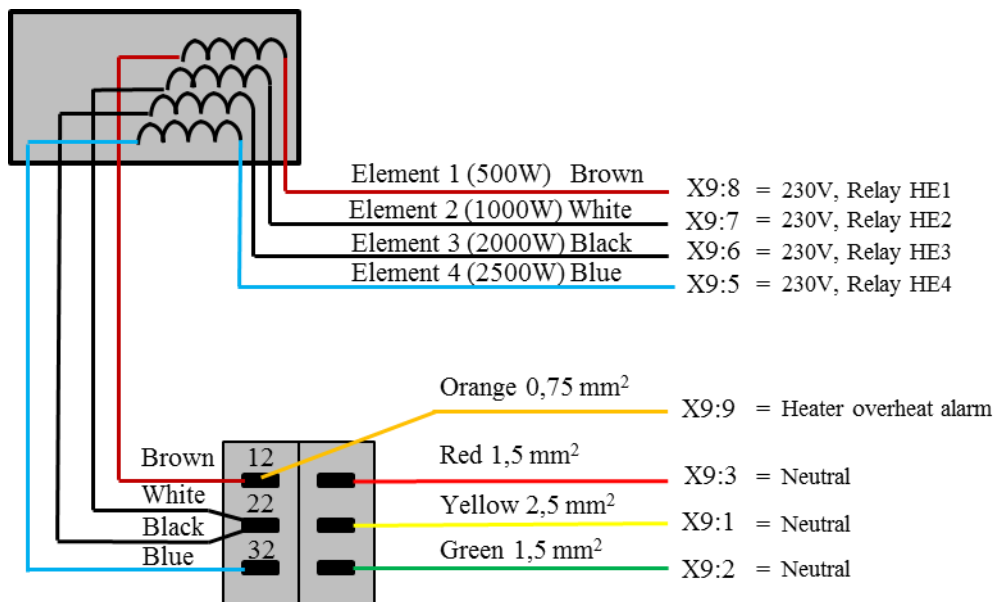

19 Components

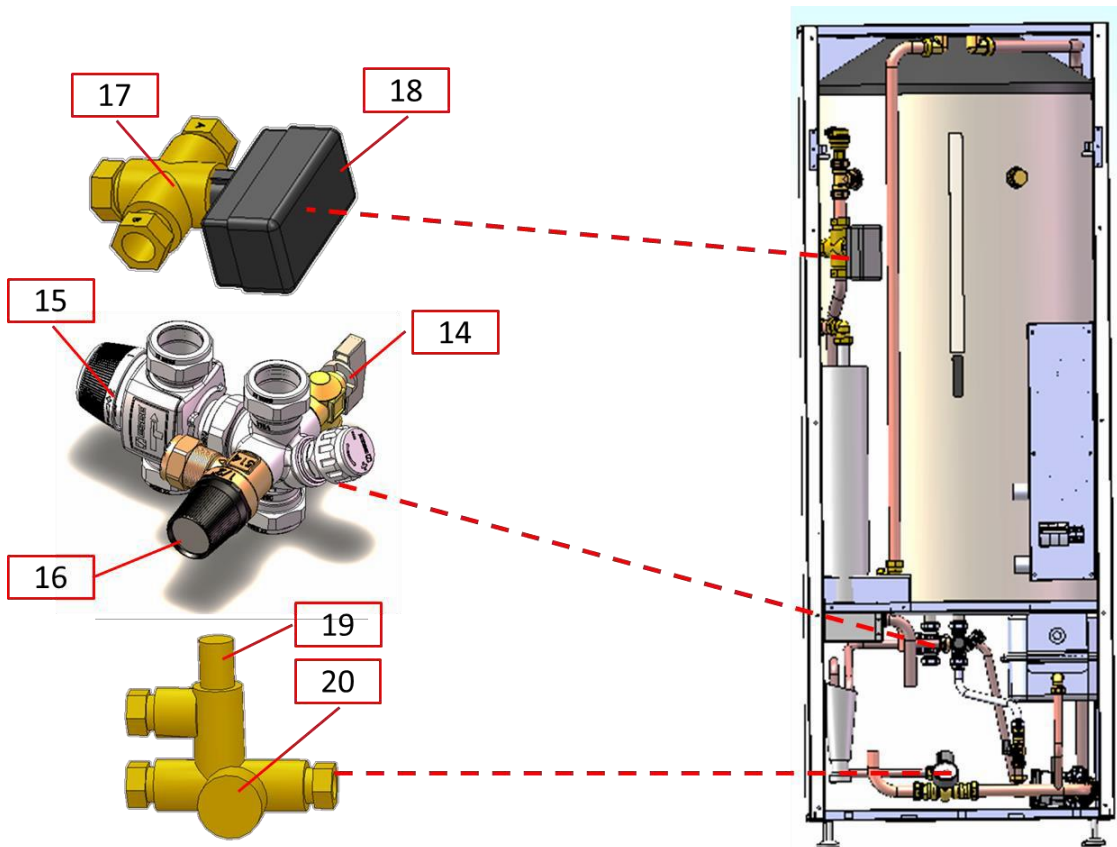
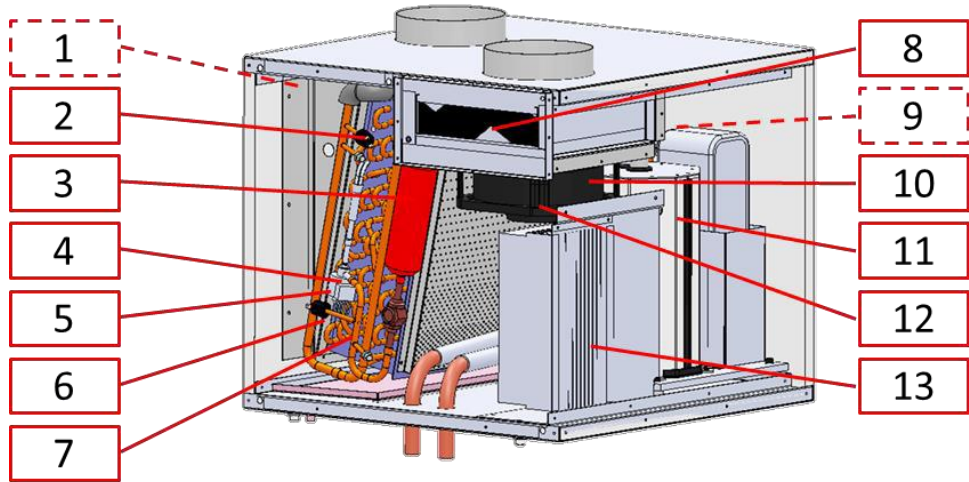

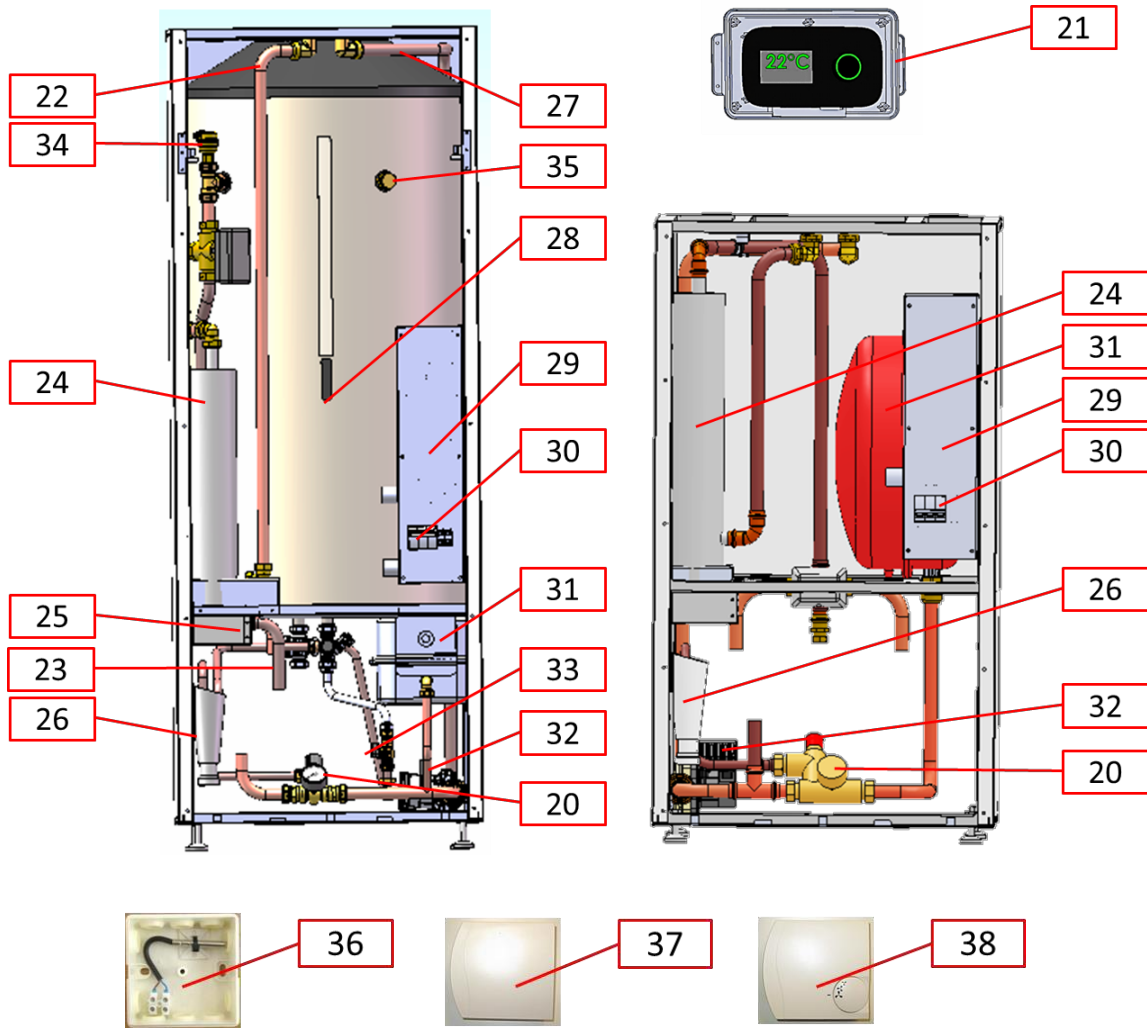

- | | |
|---|--|
| 1. 1104 Sensor TE7, extract air temp. | 21. 1869 Display unit |
| 2. 1821 Low pressure switch | 22. 2385 Sensor TE5, condenser out temp |
| 3. 1280 Drying filter | 23. 2385 Sensor TE1, supply water temp |
| 4. 1871 Expansion valve, valve | 24. 2450 Supplemental heater |
| 5. 1896 Expansion valve, motor | |
| 6. 1820 High pressure switch | 25. 1448 Supp. heater overheating protection |
| 7. 2385 Sensor TE6, evaporation temp | 26. 1197 Funnel |
| 8. 1853 Filter | 27. 2385 Sensor TE2, return water temp |
| 9. 2385 Sensor TE4, hot gas temp (hidden) | 28. 1104 Sensor TE 24, hot water temp |
| 10. 1104 Sensor TE3, indoor temp. | 29. 1868 Controller |
| 11. 1824 Compressor | 30. 1854 Main fuse |
| 12. 1873 Fan | 31. 1878 Expansion vessel |
| 13. 1967 Inverter RX35 / 50 | 32. 2230 Circulation pump |
| 2097 Inverter RX65 | 33. 1240 Filling valve 15 mm clamping ring |
| 14. 1576 Filling valve angled 90 degrees | 34. 1543 Automatic air vent |
| 15. 1892 Valve bowl. Among the back- | 35. 2489 Electric anode |
| 16. 1251 Safety valve 10 bar | |
| 17. 1232 3-way valve, valve part | |
| 18. 1231 3-way valve, motor part | |
| 19. Safety valve 10 bar (included in 2340) | |
| 20. 2340 Pressure gauge package | |
- Accessories
- | |
|--|
| 36. 1905 Outdoor sensor TE0 |
| 37. 1661 External indoor temp sensor TE3 |
| 38. 2407 Fan control with ext. indoor sensor |

20 CE declaration



Declaration of Conformity

Product articles

ComfortZone RX35
ComfortZone RX50
ComfortZone RX65
ComfortZone RX35L
ComfortZone RX50L
ComfortZone RX65L

The above products fulfil the requirements of the following directives, regulation and standards.

- **Low voltage directive 2014/35 EU**
SS-EN60335-1 (2012)
- **Electromagnetic Compatibility 2014/30/EU**
SS-EN60335-2-40 (2003), -2-40/A1 (2006), -2-40/A2 (2009),
-2-40/A11 (2004), -2-40/A12 (2005), -2-40/A13 (2003), -2-40/C1 (2006),
-2-40/C2 (2003)
SS-EN 55014-1 (2007), -1/A1 (2009), -1/A2 (2011), -2 (2002), -2/A1 (2002), -
2/A2 (2008), -2/C1 (2002), -2 IS1 (2007)
SS-EN61000-3-3 (2008)
SS-EN61000-3-2 (2006), -A1 (2009), -A2 (2009)
- **Ecodesign 2009/125/EC**
Regulation 813/2013/EU
EN 14825:2016
EN 12102:2013
EN 16147:2013
- **RoHS directive 2011/65/EU**
EN 50581:2012

21 Energy declaration

Energy declaration ComfortZone RX35 / RX50 / RX65

According to EU Commission Delegated Regulations No. 811/2013 and 518/2014.

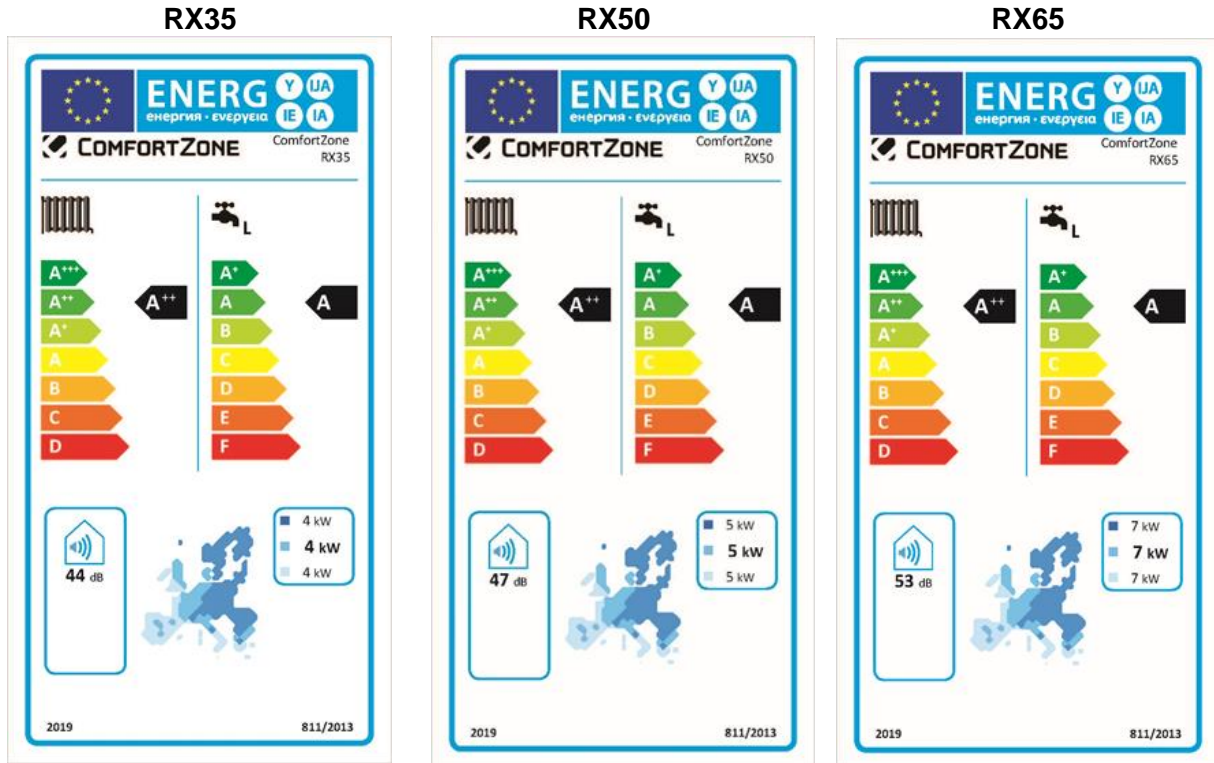

Energy consumption (per	RX35	RX50	RX65
Heating	4900 GJ**	6800 GJ**	8700 GJ**
Hot water*	4200 GJ**	4200 GJ**	4200 GJ**
Average efficiency (per			
Room heating (+ 55 ° C)			
Climate zone cooler	113 %	120 %	117 %
Climate zone medium	127 %	134 %	130 %
Climate zone warmer	129 %	139 %	134 %
Energy efficiency in hot water heating *			
Climate zone cooler	118 %	118 %	118 %
Climate zone medium	118 %	118 %	118 %
Climate zone warmer	118 %	118 %	118 %

* The figures apply to load profile L (Large) for hot water consumption according to the above regulations and refers to efficiency relative to primary energy.

In order to get the COP relative to electricity consumption, the numbers must be multiplied by 2.5.

** The unit GJ refers to GigaJoule primary energy.

1 GJ primary energy corresponds to 0.46 kWh of electricity consumption. All figures apply to climate zone medium unless otherwise stated.

22 Technical data

ComfortZone Excellence	RX35	RX50	RX65
Heat pump output out / in at 45 ° C	3,5/1,1 kW	4,8/1,6 kW	6,2/2,1 kW
Heat pump power out / in at 35 ° C	3,3/0,9 kW	4,6/1,4 kW	6,0/1,8 kW
Max heat output	9,5 kW	11,0 kW	12,5 kW
Auxiliary heater	6,0 kW	6,0 kW	6,0 kW
Fan, rated power / rated current	40W/0,40A	75W/0,68A	83W/0,75A
Refrigerant R32	950 g	950 g	950 g
Air flow at 150 Pa	75-150 m ³ /h	100-230 m ³ /h	100-330 m ³ /h
Nominal flow circulation water (20kPa)	6-33 l/min	8-33 l/min	10-33 l/min
Minimum flow of circulation water	3 l/min	3 l/min	3 l/min
Tank capacity	170 l	170 l	170 l
Sound power level	39 dB (A)	46 dB (A)	48 dB (A)
Spigots	125 mm	125 mm	160 mm
Voltage	230V-1-phase 50Hz (400V-3-phase)	230V-1-phase 50Hz (400V-3-phase)	230V-1-phase 50Hz (400V-3-phase)
Fusing	16-40A/230V (16A/3x400V)	16-40A/230V (16A/3x400V)	16-50A/230V (16A/3x400V)
Cable outdoor sensor 5-50 meters, twisted pair cable.	Min 0,25 mm ²	Min 0,25 mm ²	Min 0,25 mm ²
Expansion vessel	12 L	12 L	12 L
Preset pressure	1,0 bar	1,0 bar	1,0 bar
IP-klass	IP21	IP21	IP21
Height, tall models	2100 mm	2100 mm	2100 mm
Height, low models	1600 mm	1600 mm	1600 mm
Width	600 mm	600 mm	600 mm
Depth	650 mm	650 mm	650 mm
Weight, tall model	210 kg	210 kg	210 kg
Weight, low model	175 kg	175 kg	175 kg

23 Installation protocol

..... Installer Address Zip code / town Phone No: Customer Address Zip code / town Phone No:
--	---

Heat pump	Type:.....	Seri Nr:.....
-----------	------------	---------------

	Plumber	Value	OK	Sign
1.1	Check that the system is clean and / or dirt filter mounted.	---		
1.2	Check that the circulation water system is aerated.	---		
1.3	Check the gauge pressure, 1.0-1.5 Bar	---		
1.4	Check that any shut-off valves in the circulation water system are open.	---		
1.5	UV Pump Speed (Circulation Pump Rate in%)%		
1.6	Check that the waste water funnel is connected to the floor drain.	---		
	Electrician	Value	OK	Sign
2.1	Configure the input power limit. (Max powerW		
2.2	Control measures L1, L2 and L3 against zero and ground.	---		
2.3	Check that the heat pump is filled with water. Turn on the main switch	---		
2.4	Check that the heat pump starts up, it takes 5 minutes before the compressor starts.	---		
	Ventilation installer	Value	OK	Sign
3.1	Check that the exhaust duct is insulated with diffusion-blocked insulation.	---		
3.2	Set the fan speed. Normal. (fan effect) and enter Value.%		
3.3	Check that air flow measurement is performed, specify air flow l / s.l/s		
	Responsible installer	Value	OK	Sign
4.1	Check that the above points have been reported by the respective installer.	---		
4.2	Make sure that machine settings are complete: Go to "Advanced settings" / "Basic settings". - UV heating..... <input type="checkbox"/> Underfloor..... <input type="checkbox"/> Radiator heating. - UV Control method..... <input type="checkbox"/> IN..... <input type="checkbox"/> OUT..... <input type="checkbox"/> OUT&IN. - UV Heating curve..... - UV Pump speed..... - Fan speed. Normal..... - Effect limit Go to "Advanced Settings" / "Corrections". - TE24, enter the correction value%%W		
4.3	Check that all the housings thermostats are fully open (indoor control).	---		
4.4	Set the heat pump to the control method IN. Set the desired room temperature to 35 ° C. Let the heat pump run for about 10-15 minutes. Check that all radiators and / or floor heating coils are hot. Check that there is even temperature in all floors and in all rooms. Reset normal values for the desired room temperature.	---		

.....
 Date Responsible installer